

Technical datasheet



LL-100



Product features

- integral alignment flange
- integral dust protection
- narrow beam with low divergence
- in-field configuration and aiming accessory
- can be configured without filling or emptying the vessel
- air purge to keep lenses free from dust
- measures to the bottom of a silo
- measures vertical level

The BinMaster LL-100 is a non-contact instrument for automatically measuring the level of bulk, granular solid materials in silos and other storage vessels.

Based on laser technology with its characteristic narrow beam and low divergence, the LL-100 can measure directly to a surface without interference from internal structure and with complete immunity to surface angle or material dielectric.

The LL-100 sensor features an integral flange and swivel joint which is adjustable through an angle of $\pm 10^\circ$ making it easy to aim to the very bottom of a silo. Internal sensors compensate for this tilt angle by converting the measured distance from a "slant range" into a "vertical level". The unit can measure all clearly visible surfaces irrespective of texture, granularity, slope or colour. A still-air barrier prevents dust particles from reaching the optics and keeps the lenses clean for long periods.

The LL-100 has a USB port that can be used to input configuration and settings. This port also supplies power to the instrument in the event that field power is not available. An optional field programmer with text and graphical readouts makes it easy to visualize results, input range values and align the instrument.

Applications

The LL-100 accurately measures to the surface of mineral ores, grains, fibrous materials, synthetic plastics and numerous other materials that are stored in bulk, pellet or granular forms. By taking advantage of its long measuring range and narrow beam, the LL-100 can reach the bottom of tall silos or measure through narrow apertures into feed chutes, bunkers and hoppers.

Installation

The LL-100 is normally attached to a process connection at the top of a silo or mounted on a bracket above the material to be measured. To aim the LL-100 at the right point on the surface or down to the bottom of a silo, loosen the clamp ring on the adjustable flange and rock the body of the instrument to the correct angle. A virtual aiming laser is available as an animated graphic on the field programming accessory. Tighten the clamp ring to re-seal the process.

The LL-100 nominally uses 24 V DC field power and produces a 4...20 mA current output which is powered from the same source. Internal testing verifies the continuity of the current output and the status can be viewed on a terminal device using the USB port or on one of the graphic screens of the field programmer. If field power is not available, the USB interface can still be used to test, align and put settings into the instrument making use of power that is supplied through the port.

LL-100

Technical specifications

Performance data	
Sensing range	0,3...50 m (0,98'...164')
Resolution	10 mm (0,39")
Accuracy	1 standard deviation = 2,5 cm (0,98") at 20°C
Update rate	5 readings per second
Technical data	
Power supply	24 V DC nominal (12...28 V DC)
Current consumption	200 mA nominal
Output	
Analog	4...20 mA self-powered & non-isolated
Communication	USB 115200 baud 8-N-1
Mechanical data	
Diameter	16 cm (6,29")
Length	20,6 cm (8,11")
Weight	1,6 kg (3,52 lb.)
Process connection	NW65 flange with 4 Ø12,5 mm (0,49") holes on 130 PCD NW80 flange with 4 Ø 16,5 mm (0,63") holes on 150 PCD NW100 flange with 4 Ø 16,5 mm (0,63") holes on 170 PCD
Electrical connection	M15 x 1,5
Air purge hole	1/8" BSP option
Materials	
Housing	Anodized aluminium
Lenses	Impact resistant acrylic
Optical data	
Optical aperture	60 mm
Beam divergence	< 1° to half power points
Lens material	Impact resistant acrylic
Laser safety classification	Class 1M
CAUTION:	Do not view laser directly with optical instruments
Environmental data	
Operating temperature	-20°C...+60°C (-4...140 F.)
Pressure	Atmospheric
Enclosure rating	IP66
Approvals	
	CE 0513

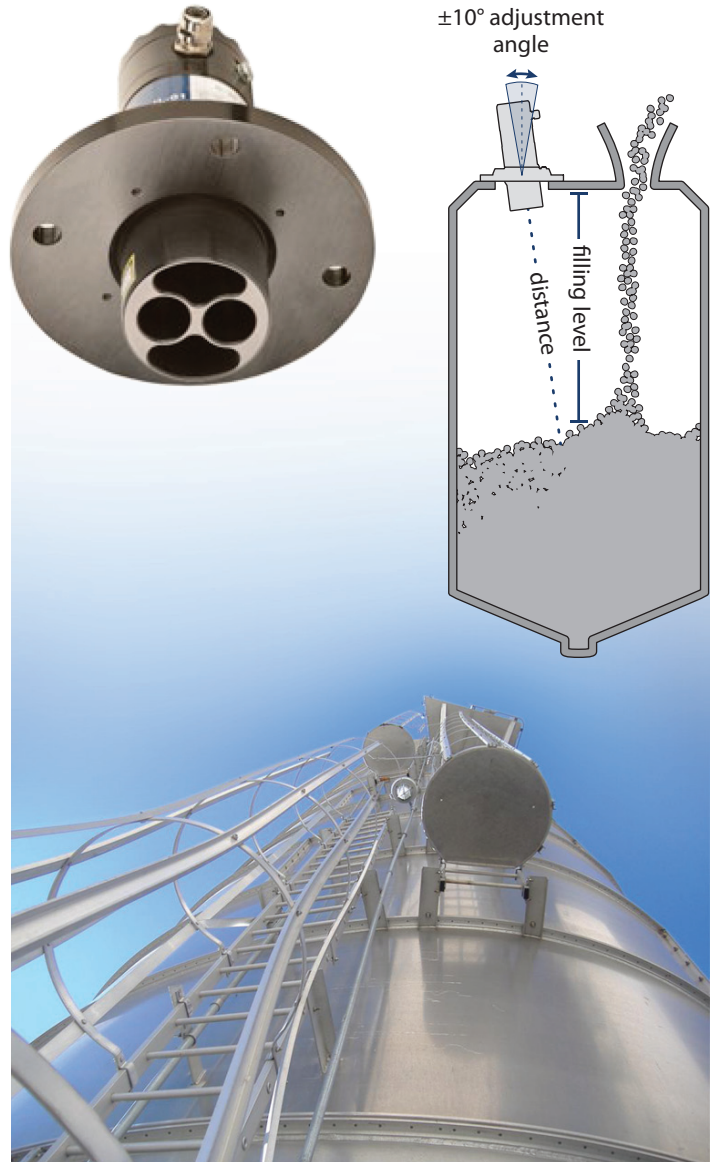

Operation

The LL-100 continuously outputs a current on the NAMUR compliant 4...20 mA channel, that is proportional to the level of the material being measured. Accurate determination of this level is the result of multiple sensing technologies feeding into a mathematical algorithm. At the heart of this algorithm is the conversion of timed laser pulses into a "slant range" followed by a secondary correction for the aiming angle of the laser beam. The resulting vertical measurement is transformed into the final level by using the absolute distances input as the 4...20 mA end points.

Limitations

The LL-100 includes filtering algorithms that remove interference from light or sporadic dust, vapours or falling materials. However, if there is too much dust or the vapour is too opaque the readings will be affected.

Simplifying solid level measurement

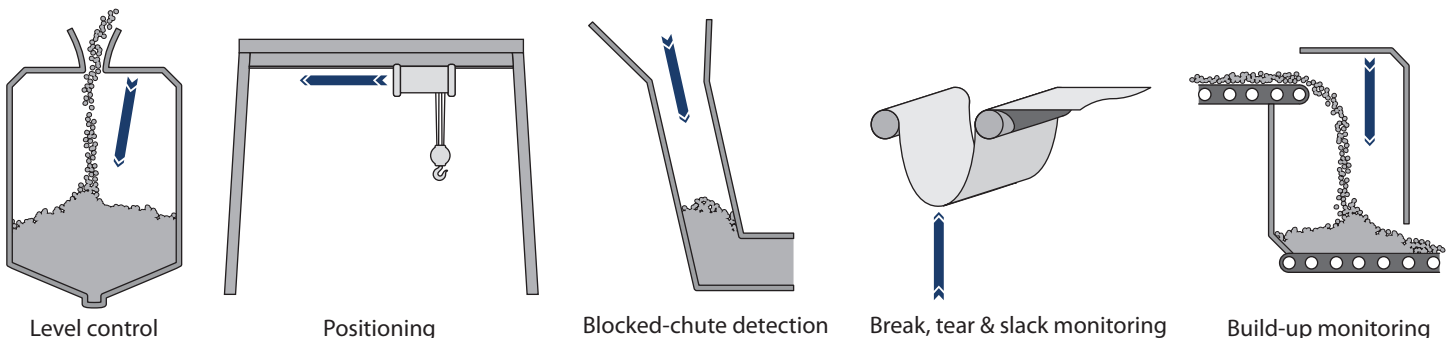

LL-100

Communication via BinMaster Terminal

- Install the latest revision of *BinMaster Terminal* software and open.
- Connect the LL-100 to a PC using a USB cable. The green power indicator LED in the LL-100's terminal compartment will light up.
- Press the *BinMaster Terminal* software "Connect" icon and the Home running screen will begin to display.
- If an automatic connection is not created, click the "Settings" icon and select the appropriate USB port.
- To access the Home screen and view details of the LL-100, press the <SPACEBAR>.
- To restart measurements, press the <SPACEBAR> again.
- To save a copy of the current screen data, click the "Save" icon.
- If you wish to start recording data, click the "Log" icon.
- To clear the screen of measurement data, click the "Clear" icon.

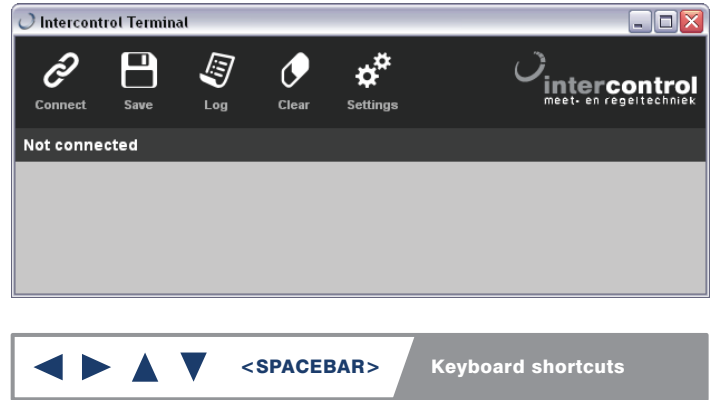

Home

```
** BinMaster **
** LL-100 **
Serial: #...

Use left and right arrow keys to
show different settings.

Select the number next to a
setting to edit the value.

Use up and down arrow keys to
go from settings to live results.
```

▲ <SPACEBAR> ▼

Home running screen

```
2.26m 18.91mA 100%
2.26m 18.91mA 100%
2.25m 18.92mA 100%
...
```

4...20 mA settings

```
*** 4...20 mA settings ***
1: 4 mA end point      25.00 m
2: 20 mA end point    0.60 m
3: NAMUR NE43 fail safe = hold
4: Fail detect time   4.0 sec
5: Output test current 18.92 mA
```

▲ <SPACEBAR> ▼

4...20 mA running screen

```
0.00m Output:18.92mA Signal:100% Connected:YES
2.26m Output:18.91mA Signal:100% Connected:YES
2.26m Output:18.91mA Signal:100% Connected:YES
...
```

Configuration

```
*** Configuration ***
1: Fill velocity      100.000 m/s
2: Measuring mode    NORMAL
3: Vertical transform OFF
```

▲ <SPACEBAR> ▼

Configuration running screen

```
Filtered:2.24m Reading:2.24m Signal:100%
Filtered:2.26m Reading:2.26m Signal:100%
Filtered:2.26m Reading:2.26m Signal:100%
...
```

The Home screen displays the product identification code and unit serial number.

Access the 4...20 mA settings by clicking the right keyboard key, or Configuration screen by clicking the left keyboard key.

View the Home running screen by clicking <SPACEBAR>. This displays the current distance reading in meters, the output current mA and the signal strength as a percentage. These results are updated at eight times per second.

After making changes to any settings, always return to the Home running screen before disconnecting the USB cable.

The 4...20 mA Settings screen has five options:

- 1: 4 mA end point - this is the distance reading that will result in 4 mA on the 4...20 mA current output.
- 2: 20 mA end point - this is the distance reading that will result in 20 mA on the 4...20 mA current output.
- 3: NAMUR NE43 fail safe - this is the current that will be transmitted by the 4...20 mA output in the event of a lost signal condition.
- 4: Fail detect time - this is the time taken between a lost signal condition and the fail safe output.
- 5: Output test current- this item is used to force a current onto the 4...20 mA output for test purposes.

View the 4...20 mA running screen by clicking <SPACEBAR>. This displays the distance reading in meters, the output current in mA, the signal strength as a percentage and the status of the connection.

The Configuration screen has three options:

- 1: Fill velocity - this is the fastest filling speed that the LL-100 will allow. It is used to limit the response to unwanted objects or dust during the filing cycle.
- 2: Measuring mode - this selection can be changed to "Boost" in order to get improved signal detection at the expense of lower accuracy and speed.
- 3: Vertical transform - select between the slope distance (OFF) and the vertical distance (ON) in order to correct for the differences in the measurements due to the LL-100 being mounted at an angle to the vertical.

View the Configuration running screen by clicking <SPACEBAR>. This displays the filtered distance reading in meters after the "Fill velocity" and the "Vertical transform" have been applied, the raw distance in meters and the signal strength as a percentage.

Non-contact level measurement sensor LL-100

Dimension drawings

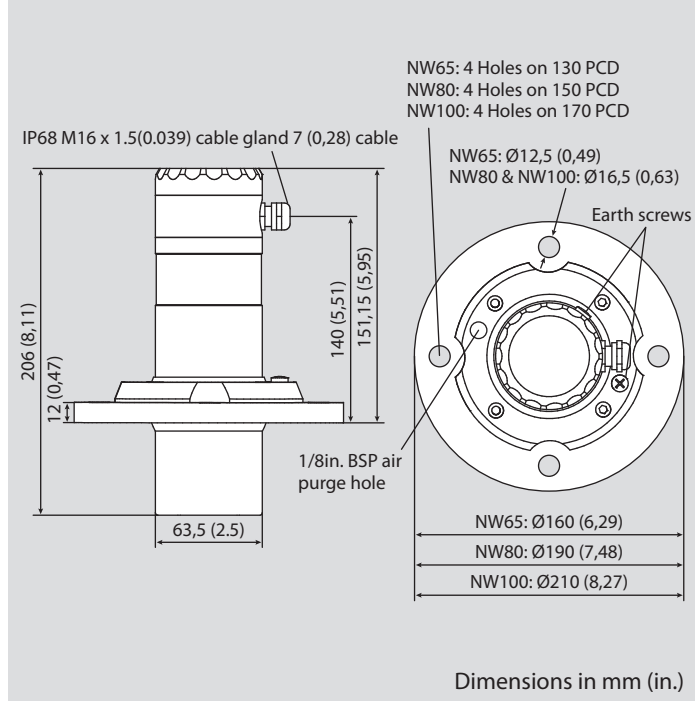

Electrical connections

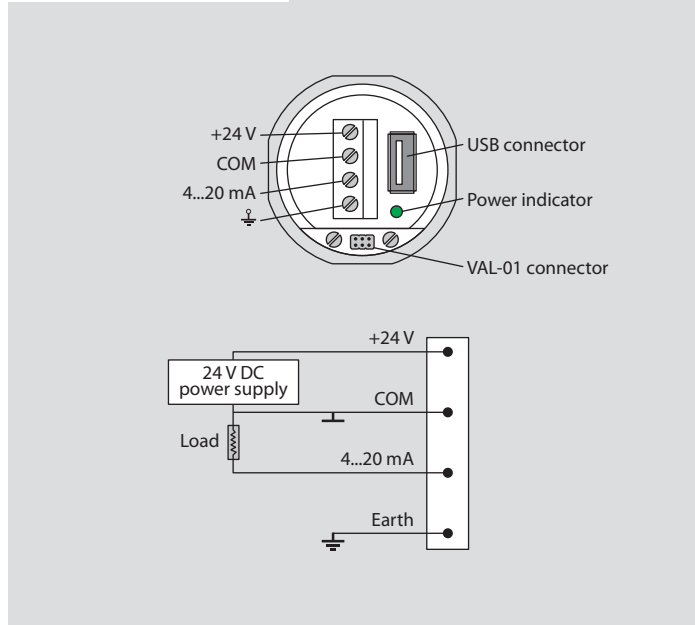

Shipping Address: 7201 N. 98th St., Lincoln, Ne 68507 / Mailing Address: P.O. Box 29709, Lincoln, NE 68529
Phone: 800-278-4241 or 402 434-9102 / Fax: 402-434-9133
www.binmaster.com / info@binmaster.com