

MXEX-IS-INST
Rev 1
04/2022



# MX SERIES OVAL GEAR FLOWMETER

Intrinsically Safe with Simple Apparatus PCB



## To the Owner

Please read and retain this instruction manual to assist you in the operation and maintenance of this product.

The manual contains operating and maintenance instructions for the MX-Series Flow Meters with Ex outputs. This covers port sizes from 1/4" to 4".

Refer to separate instruction manual for information on operating modes and features of LCD displays. Contact local representative or distributor for further assistance.

This Flow Meter has incorporated the oval gear principle into its design. Exceptional repeatability and high accuracy over a wide range of fluid viscosities and flow rates are features of the oval gear design.

With a low pressure drop and high pressure ratings, oval gear flow meters are suitable for gravity and (in-line) pump applications.

Macnaught offer a comprehensive set of web based support materials to complement this instruction manual.

Access the Instruction manual by scanning below QR code.



Important Information	Page # 3-4
Operating Principle	Page # 5
<b>Installation</b>	
Installation Instructions	Page # 5-6
Earthing Points on Flow meter	Page # 6
<b>Maintenance Procedure</b>	
Disassembly	Page # 7
Reassembly	Page # 7
Pictorial Representation	Page # 8
<b>Flow meter Specifications</b>	
Product Identification System	Page # 9
Flow meter Specifications	Page # 10
Simple Apparatus PCB	Page # 11
Intrinsically Safe Display ERX (Fx)	Page # 12-13
Intrinsically Safe Display ERAX (Gx)	Page # 14-15
Intrinsically Safe Batch Controller ERBX (Hx)	Page # 16-17
Engraving / Data Plate Information	Page # 18
Installation of Flanges	Page # 18
<b>Service</b>	
Exploded Diagrams	Page # 19
Troubleshooting Guide	Page # 20
Wetted Parts	Page # 21
Spare Parts Kits	Page # 22
<b>General</b>	
Pressure Drop Graphs	Page # 23
Dimensional Diagrams	Page # 24-26
Certificates	Page # 28-30



**EQUIPMENT CATEGORY:** The Macnaught oval gear flow meters are designed in category II 2 G according to EN 60079-0 and EN 60079-11 for use in zone 1. The inside of the measuring unit is also approved for zone 1. Macnaught declines any responsibility for the use of flow meters outside the designated Ex group, category and zone.

The flow meters shall be rigorously used within the min-max rated temperature and pressure limits specified by Macnaught. Failure to do so will result in high risk of explosion.



**EU CONFORMITY:** The manufacturer declares with the EU declaration of conformity on his own responsibility conformity with the protection goals of directive 2014/34/EU for use in hazardous areas with gas. The EU declaration of conformity for the equipment category II 2 G is based on the EU type technical file SIRA: SIRA 15XT063 Rev 4.



**POTENTIAL RISK OF EXPLOSION:**

Do not run the flow meter in conditions that would cause overheating, damage and potentially create high risk of explosion in hazardous area.

The flow meter must be protected from impact at all times: impact can cause mechanical sparking and result in high risk of ignition/explosion

The flow meter external housing can be made of Aluminium: contact between iron oxide (for example - rust iron) and aluminium can cause sparks with high risk of ignition/explosion. Ensure no source of iron oxides are available within the Ex zone where the flow meter is installed.

In the event a leakage on the flow meter is observed, process must be interrupted immediately and proper maintenance carried out. Leakages could create dry run condition in the meter with resulting risk of ignition/explosion.



**FLOWMETER USAGE:** The flow meter shall be used exclusively with fluids. No gases permitted to flow. Presence of gases could create severe hazard and damage



**FLUID COMPATIBILITY:** Before use, confirm the fluid to be used is compatible with the meter. Refer to Industry fluid compatibility charts or consult your local representative.



**SAFETY BARRIER:** Use appropriate safety barriers for outputs. Refer to below pages for Entity Parameters:

- Page 11 - Reed Switch
- Page 12 - ERX Display (Type Fx)
- Page 14 - ERAX Display (Type Gx)
- Page 16 - ERBX Display (Type Hx)



**STRAINER:** To prevent damage from dirt or foreign matter it is recommended that a Y or Basket type mesh strainer be installed as close as possible to the inlet side of the meter.

- Meter 1/4"            74 micron / 200 mesh
- Meter 1/2"- 2"      250 micron / 60 mesh
- Meter 3"- 4"        420 micron / 40 mesh

When a strainer is installed it should be regularly inspected and cleaned. Failure to keep the strainer clean will dramatically effect flow meter performance. Contact your local representative for advice.



**AIR PURGE / LINE PRESSURE:** To prevent damage caused by air purge, slowly fill the meter with fluid. To reduce pressure build-up turn off the pump at the end of each day.

Never expose the flowmeter register assembly to atmospheric agents as that may result in a deterioration of explosion protection and an increased risk of explosion.

Any alteration to the product (e.g. removal of the 3 plugs (IP67) on the housing, installation of cable glands, etc) may result in a deterioration of explosion protection and an increased risk of explosion. Macnaught will not accept any liability resulting from alterations to the product.

Only sound IP67 cable glands must be on the register housing to pull signal cable out of the register. Installation must be carried out by qualified and trained personnel only. Macnaught will not accept any liability resulting from use of cable glands.

### **INSTALLATION / SURROUNDING CONDITION**

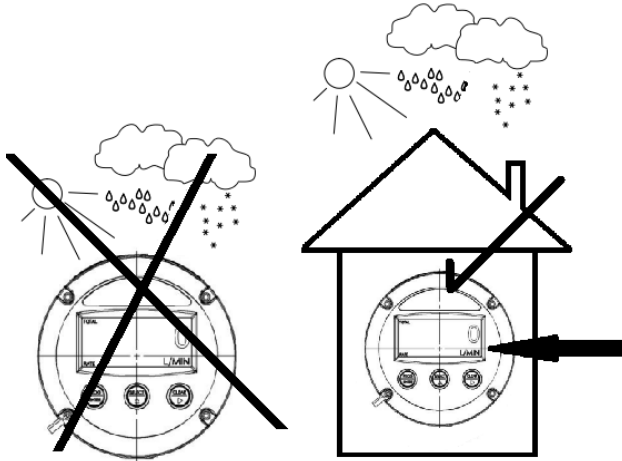

Extreme weather condition can deteriorate IP67 rated equipment

Take necessary precautions against moisture

Take actions to avoid excessive Vibrations

Relative humidity must be less than 90% RH

### **Service/Repairs:**



Don't Service/Repair on-site as that may compromised explosion proof protection. Contact Macnaught for Service/Repairs.

## OPERATING PRINCIPLE

Fluid passing through the meter causes the rotors to turn, as shown below. One of the rotors (the active rotor) is fitted with magnets.

The passing of the magnets are picked up by the electronic sensor. The excitation of this switch provides a 'Raw Pulse Output' which relates to the K-Factor. (e.g. KF 36 = 36 pulses per litre of fluid passed)

This Pulse Output Signal can either be fed to an external receiving element (e.g. Data Logger or PLC) or alternatively to an LC Display which conditions the Pulse signal to display volume of fluid passed. (e.g. Display 1 Litre per for every 36 pulses received)

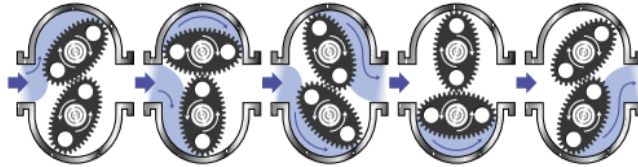

## INSTALLATION INSTRUCTIONS



**INSTALLATION:** Assembly, installation, start-up and maintenance may only be carried out according to the applicable installation standards (e.g. IEC 60079-14) by qualified personnel trained in explosion protection! The information given in the manual and these instructions must always be observed: failure to observe the instructions on this manual will result in a high risk of explosion.

The operator or his agent is responsible for observing any additional standards, directives or laws if required due to operating conditions or place of installation. This applies in particular to the use of easily detachable process connections when measuring flammable media.

When an equipment fault is detected the device shall be de-energised and send back to the manufacturer for repair.



### **EARTHING/EQUIPOTENTIAL BONDING:**

The flow meter must be included in the on-site equipotential bonding system according to EN 60079-14. Proper earthing and equipotential bonding provisions shall be in place and properly maintained on the flow meter and the whole installation, as per EN/IEC 60079-14 or any other relevant applicable standards. Failure to do so would result in high risk of static sparking and explosion. See Images on Page (5) for earthing/equipotential bonding points on flow meter.



### **ELECTROSTATIC CHARGE:**

In order to avoid ignition hazards due to electrostatic charge, flow meters may not be used in areas with:

- processes that generate strong charges,
- mechanical friction and cutting processes,
- spraying of electrons (e.g. in the vicinity of electrostatic painting systems) or
- pneumatically conveyed dust is exposed.

Electrostatic charging of the housing surface by friction must be avoided. The devices must not be dry cleaned. If you feel an electric shock while using the meter, stop dispensing immediately. Identify and correct the problem before continuing.



### **IMPORTANT NOTES:**

After installation and before start up, the flow meter must be primed and the air in the pipework purged to avoid onset of dry run conditions in the flow meter: that could cause damage and risk of explosion if persistent.

Do not install the flow meter in close proximity of a source of heat (for ex. furnace, heater) that can cause an increase of flow meter temperature: hot surfaces on the flow meter can cause risk of explosion

Proper strainers/filters shall be used to avoid debris of foreign bodies to reach the oval gears: failure to do so would result in severe damage and mechanical sparking with high risk of ignition/explosion.

## INSTALLATION INSTRUCTIONS

1. It is recommended that a bypass line be included in the design. This provides the facility for a meter to be removed for maintenance without interrupting production. (see figure)

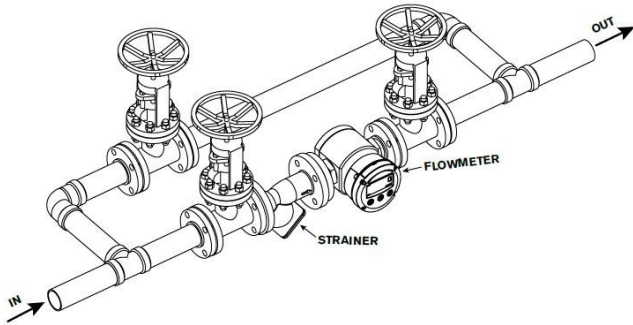

2. Use a thread sealant on all pipe threads. Thread tape must not enter flow meter, stopping flow meters operation.

3. For pump applications ensure pipe work and meter have the appropriate working pressure rating to match the pressure output of the pump. Refer to Meter Specifications section for further details.

4. Install a Y type or basket type mesh strainer as close as possible to the inlet side of the meter.

**Meter 1/4"      74 micron / 200 mesh**  
**Meter 1/2" - 2"    250 micron / 60 mesh**  
**Meter 3" - 4"      420 micron / 40 mesh**



Note ! The flow meter can accept flow in any direction.

5. The meter can be installed in any orientation as long as the meter shafts are in a horizontal plane as per the picture.

Incorrect installation can cause premature wear of meter components.

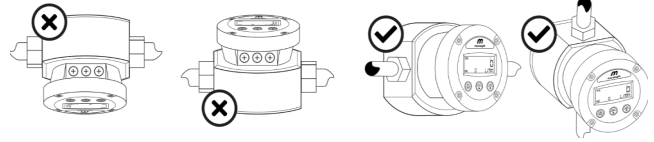

Note ! Do not over tighten meter connections.

7. It is important after initial installation to fill the line slowly, high speed air purge could cause damage to the rotors.

8. Test the system for leaks. Do not continue use if meter is leaking.

9. Check the strainer for swarf or foreign material, after the first 200 litres check periodically, particularly if the flow rate is noted to be decreasing.

## EARTHING / EQUIPOTENTIAL POINTS ON FLOWMETER

For MX06 to MX50 meters, one of the mounting hole on flow meter cap can be used as Earthing point. See below picture to locate that point:

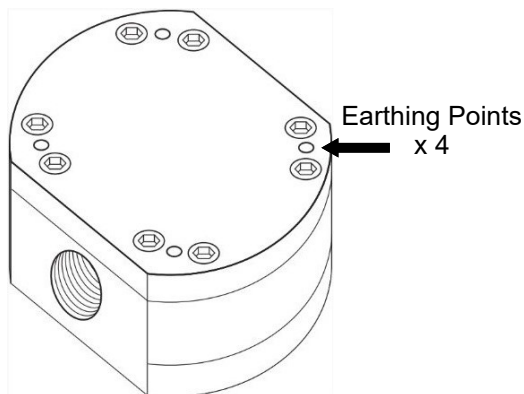

For MX75 and MX100 meters, see below pictures to locate Earthing point:

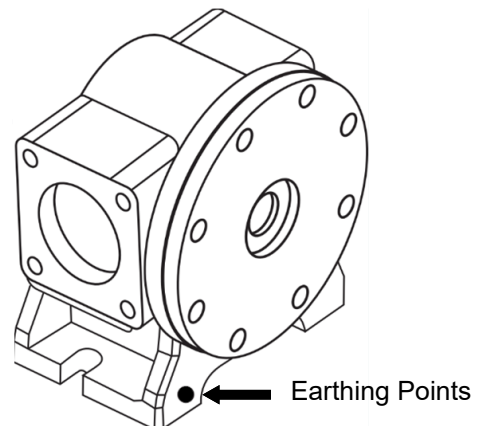

Meter	Earthing Point	Meter	Earthing Point
<b>MX06</b>	M5 x 0.80	<b>MX40</b>	M8 x 1.25
<b>MX09</b>	M5 x 0.80	<b>MX50</b>	M8 x 1.25
<b>MX12</b>	M5 x 0.80	<b>MX75</b>	M8 x 1.25
<b>MX19</b>	M6 x 1.00	<b>MX100</b>	M8 x 1.25
<b>MX25</b>	M6 x 1.00		

## MAINTENANCE PROCEDURE



Note !

Inspection and maintenance of installations should only be carried out by experienced personnel.

## DISASSEMBLY



Note !

Care should be taken not to drop, damage or impact equipment due to risk of spark. Non sparking tools should be used.

Meter should be removed from explosive atmosphere when maintenance to any part of the meter is required, the meter must be isolated and the line pressure released.



Note !

It is advisable to mark all components with a marker pen before disassembly, to ensure all the components are replaced to their correct position during the reassembly process.

1. Remove the meter cap by loosening the bolts on the underside of the meter body. (see FIG 1, Page 7)
2. Remove the O-Ring from the O-Ring groove. Wipe clean of grease and store in clean place.
3. Remove rotors from the cap and shaft assembly. The shafts are fixed to the cap for sizes 1/4" - 2" and to the body for 3" and 4" sizes. No need to take them off.



Note !

Do not remove shafts from their location.

## REASSEMBLY

1. Before reassembling, check the condition of flow meter parts (rotors, body, cap, seal O-ring and shafts). Replace if necessary. Contact Macnaught to check for spare parts availability.
2. One of the rotors is active (have magnets) and other one is neutral. The active rotor can be identified by running a metal object over the face of the rotor. Placed both the rotors at 90° to each other onto the shafts. Spin them to check if they move freely. If not, repeat the process.

- **Active Rotor Placement into Flow meter:**

- **MX06 - MX09 Meters:**

- The active rotor is positioned nearest to 'dimple' on the meter cap. (see FIG 2, Page 7)

- The smooth side of rotor showing up, grub screw will face downwards.

- The chamfered side of the rotor stays upward when placed on to the shaft (see FIG 6, Page 7)

- **MX12 - MX50 Meters:**

- The active rotor is positioned nearest to 'dimple' on the meter cap. (see FIG 2, Page 7)

- Meter cap dimple must face towards the flow meter body dimple. (see FIG 2 & 3, Page 7)

- The magnet side face upward when placed on the cap.

- **For MX75 - MX100 meters:**

- Active rotor is positioned on to the shaft away from the flow meter foot. (see FIG 7, Page 7)

- The magnet side of the active rotor face upward when placed inside the flow meter body.

3. Smear the O-ring with light film of grease and placed into the Groove. (see FIG 3, Page 7)
4. Place the meter Cap on the meter Body.  
Meter cap dimple must face towards the flow meter body dimple (MX06-MX50 Meters). (see FIG 2 & 3, Page 7)
5. Insert the cap head screws and tighten in a diagonal sequence 1, 5, 7, 3, etc.

- **Bolts Torque Ratings:**

- MX06-MX12 (6.5 Nm)

- MX19-MX25 (15 Nm)

- MX40-MX100 (33 Nm)

6. Test the meter by turning the rotors with a finger or by applying very low air pressure (no more than a good breath) to one end of the meter, before returning the meter to service.

# PICTORIAL REPRESENTATION OF FLOWMETER AND DISASSEMBLED PARTS

**Flow meter  
FIG 1**

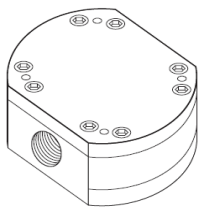

**Flow Meter Cap  
FIG 2**

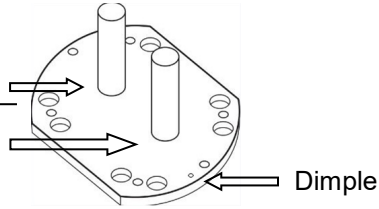

Shafts

Dimple

**Flow meter Body  
FIG 3**

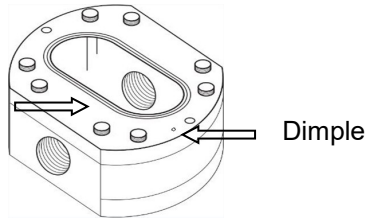

Groove

Dimple

**Rotors (At 90°)  
FIG 4**

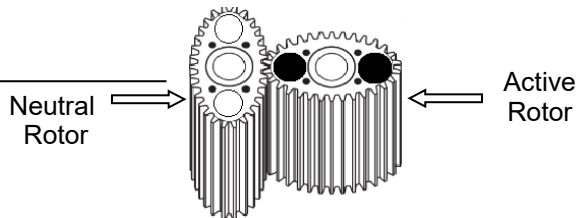

Neutral Rotor

Active Rotor

**O-ring  
FIG 5**

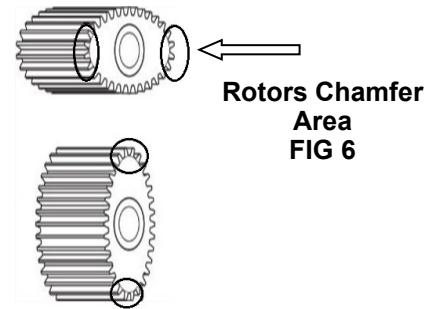

**Rotors Chamfer Area  
FIG 6**



Note !

For MX06 and MX09 meters, the flat side of rotors with chamfer on edges face upward when placed on cap and shaft assembly of meter

## MX75 - MX100 Meters

**FIG 7**

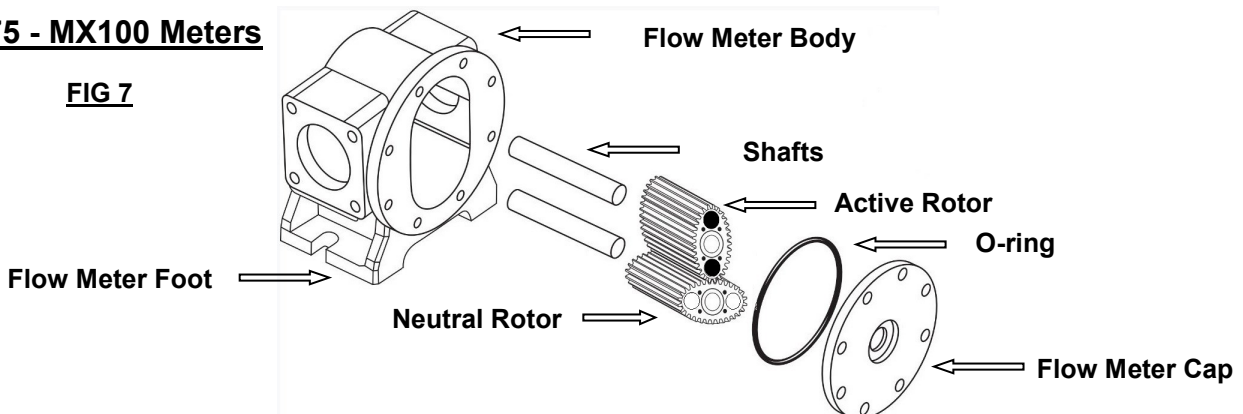

Flow Meter Body

Shafts

Active Rotor

O-ring

Flow Meter Cap

Neutral Rotor

Flow Meter Foot



# PRODUCT IDENTIFICATION SYSTEM

Series	MX								
MX Port Size	06	1/4"							
	09	1/4"							
	12	1/2"							
	19	3/4"							
	25	1"							
	40	1 1/2"							
	50	2"							
	75	3"							
	100	4"							
Category	P	SS/SS/FEP SS/PEEK/FEP	MX06-MX50						
		AL/SS/FEP AL/PEEK/FEP	MX06 - MX25						
		AL/AL/FEP AL/PEEK/FEP	MX40 - MX100						
-	-								
Port Connection	1	2	3	4	5	6	G threads	MX06-MX100 3" BSP and NPT port connection for MX100	
							NPT threads		
							ANSI 150# Flanges	MX25 - MX100	
							JIS 10k Flanges		
							DIN PN 16k Flanges		
							BSP (Rc) Threads	MX06, MX09, MX12 and MX25	
Rotor Type	P	S	T	V	Fx	Gx	Hx	PEEK	MX19S-MX50S MX19P-MX50P
								Standard	MX06-MX25 (SS) MX40-MX100 (AL)
								SS	MX06P-MX50P
								High Viscosity (SS / AL)	MX09S-MX100S MX09P-MX50P
Output Type	P	S	T	V	Fx	Gx	Hx	Ex Approved (NPN) sensor (Ex ia)	
								Ex Approved (NPN) sensor (Ex d)	
								Ex Approved (NAMUR) sensor (Ex ia)	
Example	MX	06	P	-	2	T	Fx		

## FLOWMETER SPECIFICATIONS

Flow Meter Series	Flow Range (Viscosity < 5 cP)		Flow Range (Viscosity > 5 cP)	
	Metric	US	Metric	US
<b>MX06</b>	2 to 100 LPH	0.5 to 26 GPH	0.5 to 100 LPH	0.13 to 26.4 GPH
<b>MX09</b>	25 to 500 LPH	6.6 to 132 GPH	15 to 500 LPH	4 to 132 GPH
<b>MX12</b>	3 to 25 LPM	0.8 to 6.6 GPM	2 to 30 LPM	0.5 to 8 GPM
<b>MX19</b>	8 to 70 LPM	2 to 18.5 GPM	3 to 80 LPM	0.8 to 21 GPM
<b>MX25</b>	10 to 100 LPM	2.6 to 26 GPM	6 to 120 LPM	1.6 to 32 GPM
<b>MX40</b>	15 to 235 LPM	4 to 62 GPM	10 to 250 LPM	2.6 to 66 GPM
<b>MX50</b>	15 to 500 LPM	4 to 130 GPM	15 to 500 LPM	4 to 130 GPM
<b>MX75</b>	60 to 600 LPM	17 to 170 GPM	20 to 733 LPM	5 to 194 GPM
<b>MX100</b>	220 to 1000 LPM	60 to 250 GPM	120 to 1200 LPM	30 to 300 GPM



Note !

Ensure the Flow meter is fitted with 'High Viscosity Rotors' if the fluid being metered is 1000 cP or above.

Temperature Range & Accuracy	
Temperature Range (MX06P - MX50P)	-40°C - 70°C
Temperature Range (MX06S - MX100S)	-40°C - 70°C
Accuracy (MX06 - MX100)	±0.5% of reading

Flow Meter Series	Maximum Operating Pressure* (Flow meter <b>Threaded</b> )		Maximum Operating Pressure* (Flow meter <b>Flanged**</b> )	
	kPa	psi	kPa	psi
<b>MX06</b>	6895	1000	-	-
<b>MX09</b>	6895	1000	-	-
<b>MX12</b>	13790	2000	-	-
<b>MX19</b>	13790	2000	-	-
<b>MX25</b>	13790	2000	1250	181
<b>MX40</b>	10342	1500	1250	181
<b>MX50</b>	8274	1200	1250	181
<b>MX75</b>	1200	175	1200	175
<b>MX100</b>	1200	175	1200	175



Note !

\* Conforms to Directive 2014/68/EU

\*\* Flanges Standard (ASME B16.5, Group 2-2.3 Materials)

The flowmeter is fitted with Simple Apparatus PCB (MX1R-IS) that conforms to the demands of Intrinsically Safe environment.

Simple apparatus PCB is an electronic board fitted with Dual Reed Switches with 20-25 cm of wire (Alpha wire 3464C or better)

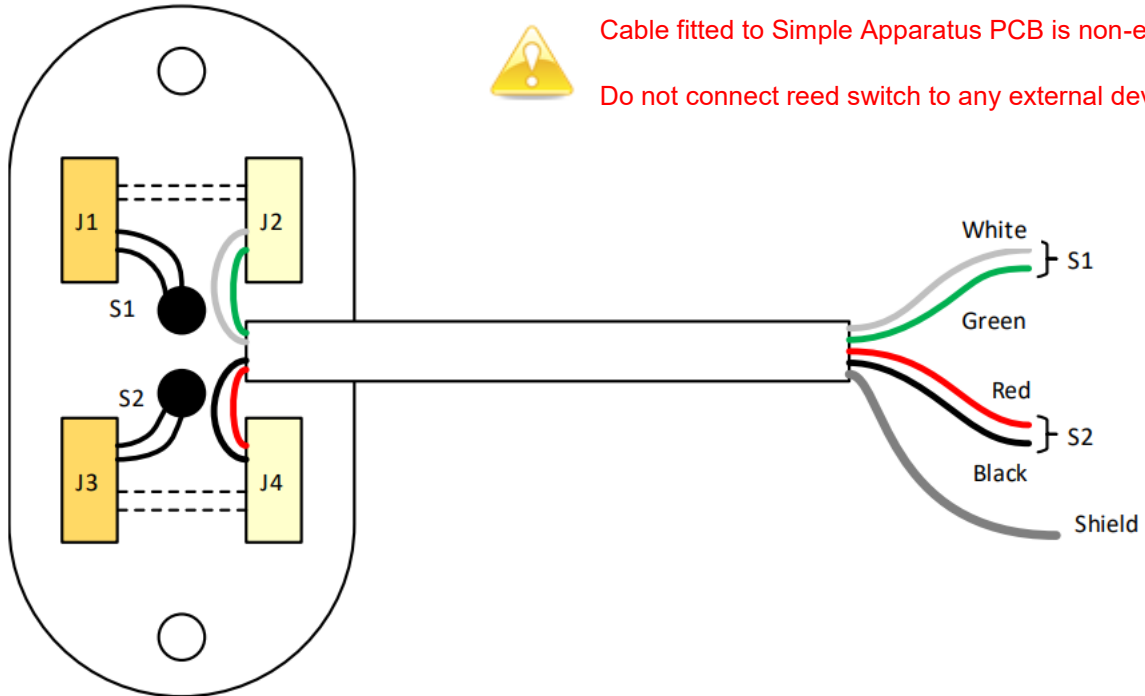

Cable fitted to Simple Apparatus PCB is non-extendable

Do not connect reed switch to any external device

	Ground	Signal
Reed Switch S1	Green + Shield	White
Reed Switch S2	Black + Shield	Red

The MX1R-IS module is designed according to IEC 60079-0:2018 and IEC 60079-11:2012. It is completely passive, adds no energy to the circuits connected and complies with the applicable clauses for Simple Apparatus (per IEC 60079-11) when used in conjunction with the Intrinsically Safe display

Both reed switch input circuits of the MX1R-IS module, are suitable for use as simple apparatus in type of protection intrinsic safety Ex ia IIC, only for connection to certified intrinsically safe circuits, with following maximum values:

$U_i = 10 \text{ V}$        $L_i = 0 \text{ mH}$

$I_i = 50 \text{ mA}$        $C_i = 0 \text{ }\mu\text{F}$

$P_i = 200 \text{ mW}$



This product cannot be repaired by the user and must be replaced with an equivalent certified product. Repairs should only be carried out by the manufacturer or his authorized agent.



Before Replacing/installing MX1R-IS board, the service man/installer must discharge himself by touching a well-grounded object.



The MX1R-IS module must be installed in accordance with the EMC guidelines (Electro Magnetic Compatibility).



The relative humidity must be less than 90% RH.

**Type Fx** is an Intrinsically Safe digital register with a 17mm LCD display, providing real-time indication of Flow rate, total (resettable) and accumulated total (non-resettable).

This display is IECEx, ATEX, CSA Canada and FM USA certified.

Locally mount to Macnaught Oval Gear Flowmeter with a Simple Apparatus PCB

The flowmeter with Simple Apparatus PCB and Intrinsically Safe display is IP67 rated

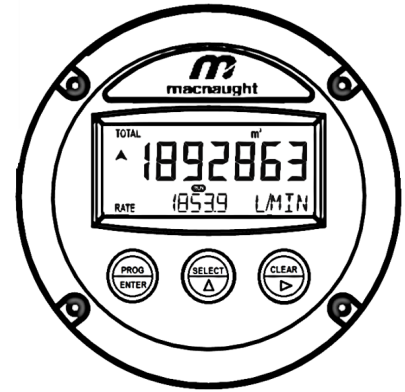

Macnaught **type Fx** display uses:

Fluidwell Intrinsically Safe display electronic PN: **F012-P-HR-PC-PD-XI-ZB**

**Wiring Instructions reference**

[www.fluidwell.com/assets/downloads/Manuals/FW-F012-P-M\\_v0404\\_01\\_EN.pdf?](http://www.fluidwell.com/assets/downloads/Manuals/FW-F012-P-M_v0404_01_EN.pdf?)



Use this Instructions Manual if further details are required

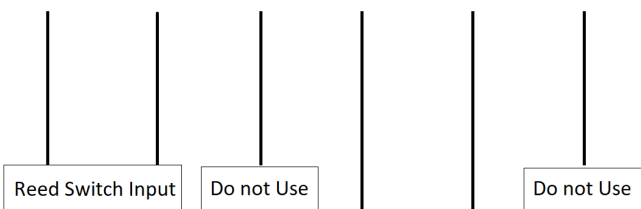
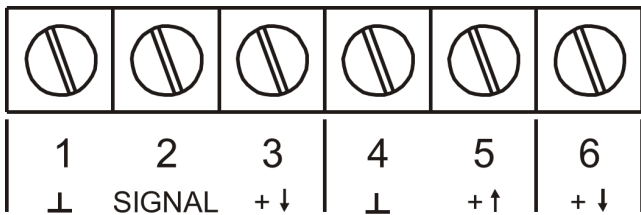

To supply power to the display, 16-30 VDC is required through an approved safety barrier

Uo = Max 30 VDC  
Io = Max 200 mA  
Po = Max 1.2 W

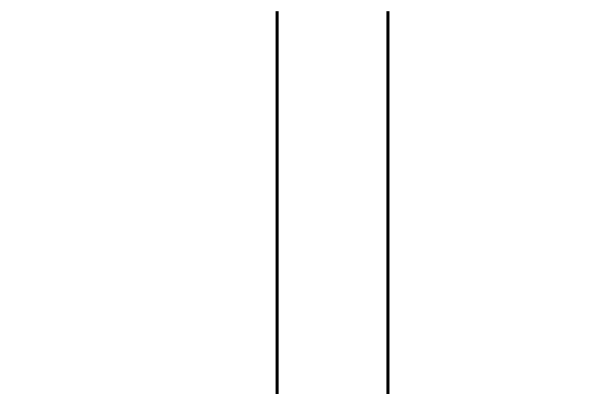
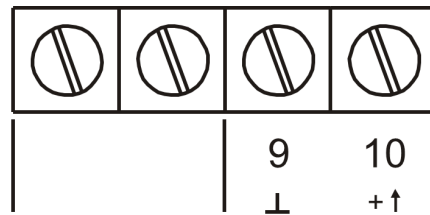

To Turn on Backlight, 20-30 VDC (Max Current: 30 mA) is required through an approved safety barrier

Uo = Max 30 VDC  
Io = Max 200 mA  
Po = Max 0.75 W

Ensure that the measuring system is correctly wired up according to the wiring diagrams. The housing may only be opened by trained personnel

This product cannot be repaired by the user and must be replaced with an equivalent certified product. Repairs should only be carried out by the manufacturer or his authorized agent.



**For Programming**, press PROG/ENTER button for 7 seconds.

Press CLEAR button to access functions and Press SELECT button to reach sub-functions

Setting up a value in sub function, press PROG and get use of buttons CLEAR & SELECT to adjust a value

Once the desired value is adjusted, press PROG button to finalize it

Once all sub functions are set, press PROG button for 3 seconds to go back to operational mode

SETUP FUNCTIONS AND VARIABLES			
<b>1</b>	<b>TOTAL</b>		
	11	UNIT	L - m <sup>3</sup> - kg - lb - GAL - USGAL - bbl - no unit
	12	DECIMALS	0 - 1 - 2 - 3 (Ref: displayed value)
	13	K-FACTOR	0.000010 – 9,999,999 (As per Flowmeter report)
	14	DECIMALS K-FACTOR	0 – 6 (This setting depend upon setting 24)
<b>2</b>	<b>FLOW RATE</b>		
	21	UNIT	mL - L - m <sup>3</sup> - mg - g - kg - ton - GAL - bbl - lb - cf - REV - no unit - scf - Nm <sup>3</sup> - NL – P
	22	TIME UNIT	sec - min - hour - day
	23	DECIMALS	0 - 1 - 2 - 3 (Ref: displayed value)
	24	K-FACTOR	0.000010 - 9,999,999 (As per Flowmeter report)
	25	DECIMALS K-FACTOR	0 - 6 (This setting depend upon setting 24)
	26	CALCULATION	per 1 - 255 pulses
	27	CUTT-OFF	0.1 - 999.9 seconds
<b>3</b>	<b>DISPLAY</b>		
	31	FUNCTION	Total - Flowrate
	32	BACKLIGHT (OPTIONAL)	Off - Green - Amber
	33	BL. BRIGHTNESS	1 – 5
<b>4</b>	<b>POWER MANAGEMENT</b>		
	41	LCD UPDATE	Fast - 1 sec - 3 sec - 15 sec - 30 sec - off
	42	BATTERY MODE	Operational – Shelf
<b>5</b>	<b>FLOWMETER</b>		
	51	SIGNAL	REED_LP
<b>6</b>	<b>OTHERS</b>		
	61	TYPE / MODEL	F012 (Don't touch)
	62	SOFTWARE VERSION	MCN0121 (Don't touch)
	63	SERIAL NO.	123456 ((Don't touch))
	64	PASS CODE	0000 – 9999 (Change if required)
	65	TAG NUMBER	0000000 – 9999999 (Don't touch)

**Type Gx** is an Intrinsically Safe digital register with a 17mm LCD display, providing real-time indication of Flow rate, total (resettable) and accumulated total (non-resettable). The output include a 4-20mA and scaled pulse output.

This display is IECEx, ATEX, CSA Canada and FM USA certified.

Locally mount to Macnaught Oval Gear Flowmeter with a Simple Apparatus PCB

The flowmeter with Simple Apparatus PCB and Intrinsically Safe display is IP67 rated

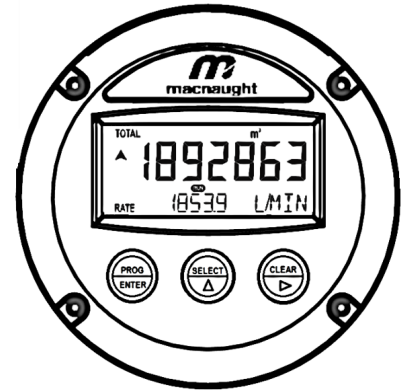

Macnaught **type Gx** display uses:

Fluidwell Intrinsically Safe display electronic PN: **F110-P-AP-CX-HR-IX-OT-PC-PD-XI-ZX**

**Wiring Instructions reference**

[www.fluidwell.com/assets/downloads/Manuals/FW\\_F110P\\_v1901\\_02\\_EN.pdf?](http://www.fluidwell.com/assets/downloads/Manuals/FW_F110P_v1901_02_EN.pdf?)

Use this Instructions Manual if further details are required

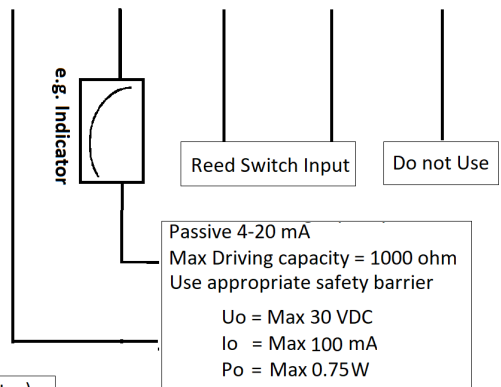
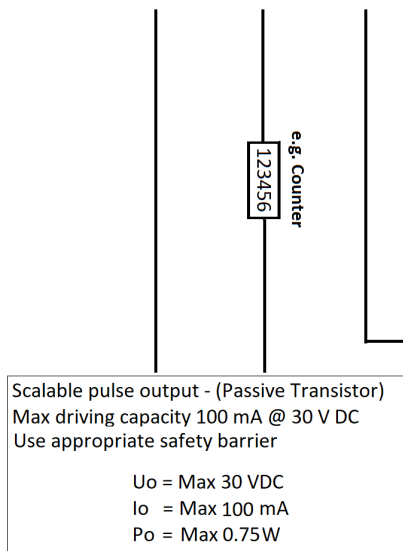
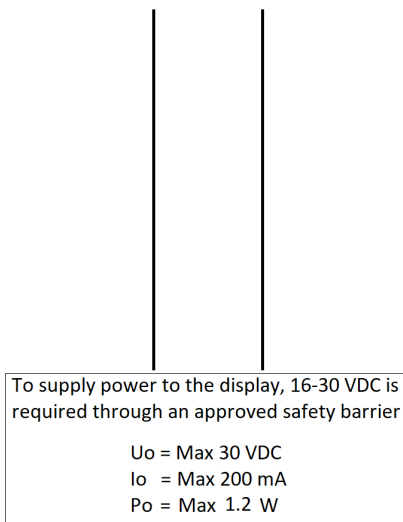
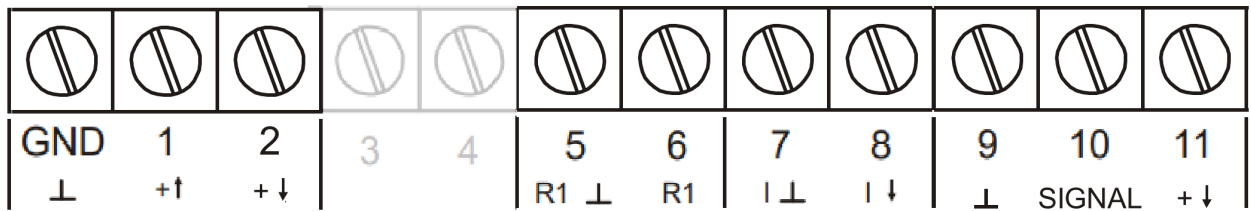

Ensure that the measuring system is correctly wired up according to the wiring diagrams. The housing may only be opened by trained personnel

This product cannot be repaired by the user and must be replaced with an equivalent certified product. Repairs should only be carried out by the manufacturer or his authorized agent.



**For Programming**, press PROG/ENTER button for 7 seconds. Press CLEAR button to access functions and Press SELECT button to reach sub-functions. Setting up a value in sub function, press PROG and get use of buttons CLEAR & SELECT to adjust a value. Once the desired value is adjusted, press PROG button to finalize it. Once all sub functions are set, press PROG button for 3 seconds to go back to operational mode

SETUP FUNCTIONS AND VARIABLES			
<b>1</b>	<b>TOTAL</b>		
	11	unit	L - m <sup>3</sup> - kg - lb - GAL - USGAL - bbl - no unit
	12	decimals	0 - 1 - 2 - 3 (Ref: displayed value)
	13	k-factor	0.000010 – 9,999,999 (As per Flowmeter report)
	14	decimals k-factor	0 – 6 (This setting depend upon setting 24)
<b>2</b>	<b>FLOW RATE</b>		
	21	unit	mL - L - m <sup>3</sup> - mg - g - kg - ton - GAL - bbl - lb - cf - REV - no unit - scf - Nm <sup>3</sup> - NL - P
	22	time unit	sec - min - hour - day
	23	decimals	0 - 1 - 2 - 3 (Ref: displayed value)
	24	k-factor	0.000010 - 9,999,999 (As per Flowmeter report)
	25	decimals k-factor	0 - 6 (This setting depend upon setting 24)
	26	calculation	per 1 - 255 pulses
	27	cut-off	0.1 - 999.9 seconds
<b>3</b>	<b>DISPLAY</b>		
	31	function	total; rate
	32	light	0% (off); 20%; 40%; 60%; 80%; 100% (full brightness)
<b>4</b>	<b>POWER MANAGEMENT</b>		
	41	LCD update	Fast - 1 sec - 3 sec - 15 sec - 30 sec - off
	42	battery mode	Operational - Shelf
<b>5</b>	<b>FLOWMETER</b>		
	51	signal	NPN - NPN_LP - REED - REED_LP
<b>6</b>	<b>ANALOG</b>		
	61	output	disable - enable
	62	Rate-min	0000.000 - 9,999,999 unit/time unit
	63	Rate-max	0000.000 - 9,999,999 unit/time unit
	64	cut-off	0.0 - 9.9%
	65	tune min – (0)4ma	0 - 9,999
	66	tune max- 20ma	0 - 9,999
	67	filter	00 - 99
<b>7</b>	<b>IMPULSE</b>		
	71	width	0.000 - 9.999 sec (0 = Off)
	72	decimals	0000000; 111111.1; 22222.22; 3333.333
	73	amount	0.001 - 9999999

**Type Hx** is an Intrinsically Safe is a digital register with a 17mm LCD display, providing a control output with 1 x NPN type transistor, for single stage batching applications.

This display is IECEx, ATEX, CSA Canada and FM USA certified.

Locally mount to Macnaught Oval Gear Flowmeter with a Simple Apparatus PCB

The flowmeter with Simple Apparatus PCB and Intrinsically Safe display is IP67 rated

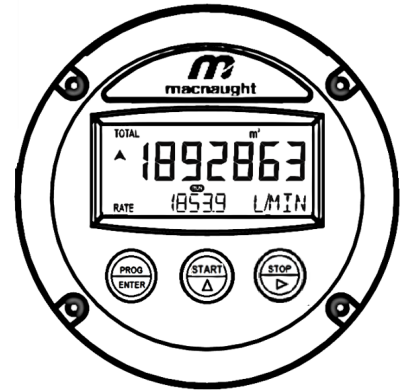

Macnaught **type Hx** display uses:

Fluidwell Intrinsically Safe display electronic PN: **F030-P-HR-OT-PC-PD-XI-ZB**

**Wiring Instructions reference**

[www.fluidwell.com/assets/downloads/Manuals/FW-F030-P-M\\_v0404\\_01\\_EN.pdf?](http://www.fluidwell.com/assets/downloads/Manuals/FW-F030-P-M_v0404_01_EN.pdf?)



Use this Instructions Manual if further details are required

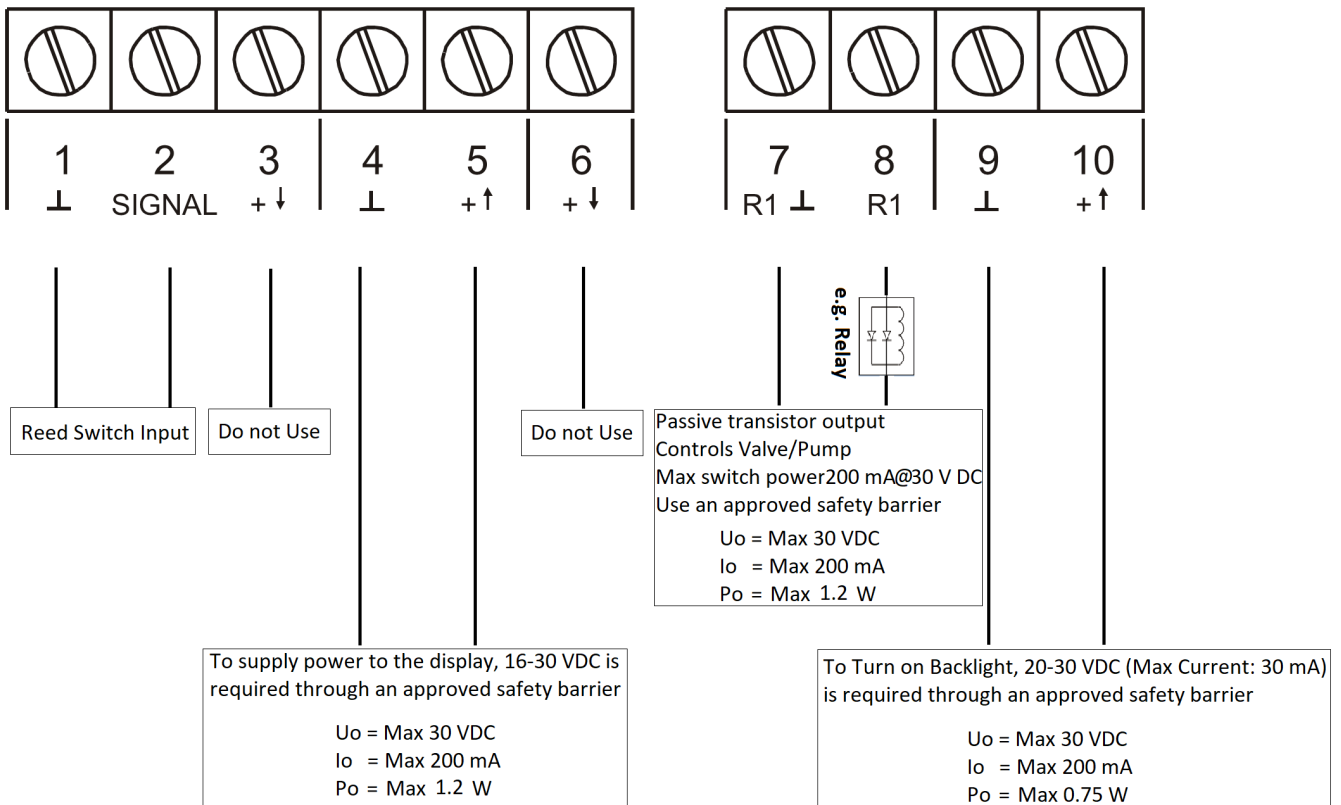

Ensure that the measuring system is correctly wired up according to the wiring diagrams. The housing may only be opened by trained personnel

This product cannot be repaired by the user and must be replaced with an equivalent certified product. Repairs should only be carried out by the manufacturer or his authorized agent.





**For Programming**, press PROG/ENTER button for 7 seconds.

Press STOP button to access functions and Press START button to reach sub-functions

Setting up a value in sub function, press PROG and get use of buttons START & STOP to adjust a value

Once the desired value is adjusted, press PROG button to finalize it

Once all sub functions are set, press PROG button for 3 seconds to go back to operational mode

SETUP FUNCTIONS AND VARIABLES			
<b>1</b>	<b>TOTAL</b>		
	11	UNIT	L - m <sup>3</sup> - kg - lb - GAL - USGAL - bbl - no unit
	12	DECIMALS	0 - 1 - 2 - 3 (Ref: displayed value)
	13	K-FACTOR	0.000010 – 9,999,999 (As per Flowmeter report)
	14	DECIMALS K-FACTOR	0 – 6 (This setting depend upon setting 24)
	15	BATCH MAXIMUM	X,XXX,XXX Quantity
<b>2</b>	<b>FLOW RATE</b>		
	21	OVERRUN	Disable - Enable
	22	TIME	0.1 - 999.9 seconds
<b>3</b>	<b>DISPLAY</b>		
	31	FUNCTION	Total - Flowrate
	32	BACKLIGHT (OPTIONAL)	Off - Green - Amber
	33	BL. BRIGHTNESS	1 – 5
<b>4</b>	<b>POWER MANAGEMENT</b>		
	41	LCD UPDATE	Fast - 1 sec - 3 sec - 15 sec - 30 sec - off
	42	BATTERY MODE	Operational – Shelf
<b>5</b>	<b>FLOWMETER</b>		
	51	SIGNAL	REED_LP
<b>6</b>	<b>OTHERS</b>		
	61	TYPE / MODEL	F030 (Don't touch)
	62	SOFTWARE VERSION	MCN0121 (Don't touch)
	63	SERIAL NO.	12345 (Don't Touch)
	64	PASS CODE	0000 – 9999 (Change If required)
	65	TAG NUMBER	0000000 – 9999999 (Don't touch)

## Flow meter Specs / Data Plate

**MX06-MX50:** Serial number, Model number, k-factor, flow rate range and temperature details are engraved on meter body. See below FIG

**MX75-MX100:** Serial number, Model number, k-factor, flow rate range and temperature details are engraved on flow meter data plate. See below FIG

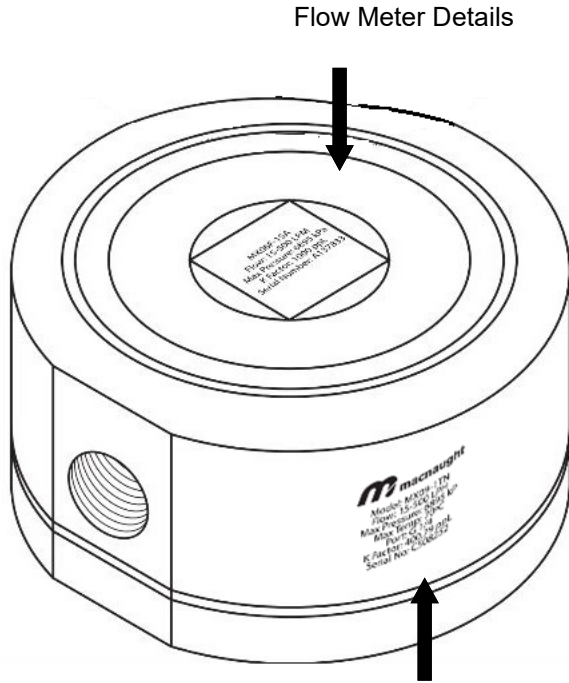

Flow Meter Details

Flow Meter Details

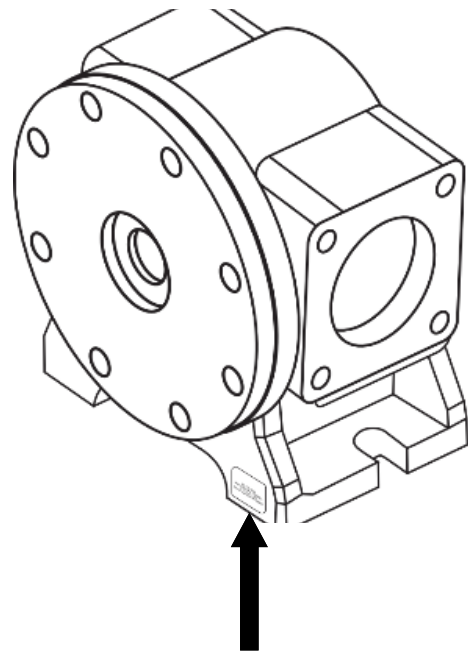

Flow Meter Details

<b>macnaught</b>	
Model:	MX75F-1SA
Flow Range	20 - 733 LPM
Max Pressure	1200 kPa
Max Temp	80°C
Port Size	G 3
Serial No.	C123456

## INSTALLATION OF FLANGES ON MX25, MX40 AND MX50 METERS

1. The locknut, gasket, O-ring and retaining ring to be fitted as shown in the below picture. Make sure that the O-rings and gaskets must not have any damages.
2. Both flanges to be equally screwed to the meter body meeting end to end dimensions and bolt pattern on the flange face
3. The lock nuts to be tightened to a specified torque as mentioned in the below table



Note!

Use a good quality grease for Gasket & O-ring and a good quality anti-crease on flange threads

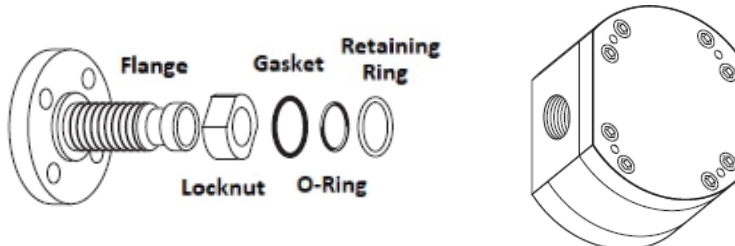

Meter	Lock Nut Torque	ANSI / ASTM	DIN	JIS	End to End
MX25	20 Nm	1" 150 LB B16.5	DN25 PN 16 EN1092-1	25A 10K JIS B 2220	240 mm
MX40	30 Nm	1.5" 150 LB B16.5	DN40 PN 16 EN1092-1	40A 10K JIS B 2220	240 mm
MX50	40 Nm	2" 150 LB B16.5	DN50 PN 16 EN1092-1	50A 10K JIS B 2220	264 mm

## EXPLODED DIAGRAM (Models MX06-MX50)

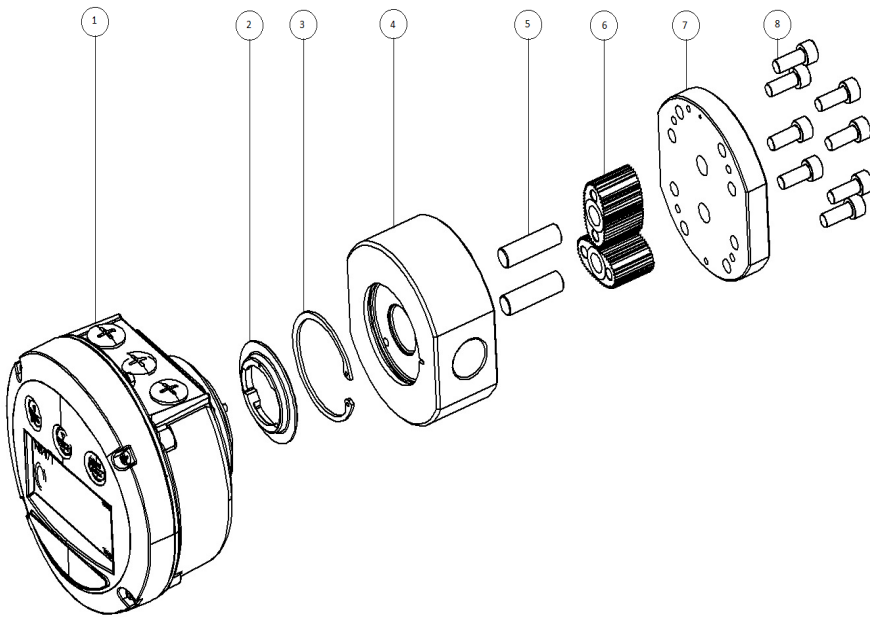

METER COMPONENTS	ITEM NO
Display	1
CAM	2
CIRCLIP	3
METER BODY	4
ROTOR SHAFTS	5
ROTORS	6
METER CAP	7
METER CAP SCREWS	8

## EXPLODED DIAGRAM (Models MX75-MX100)

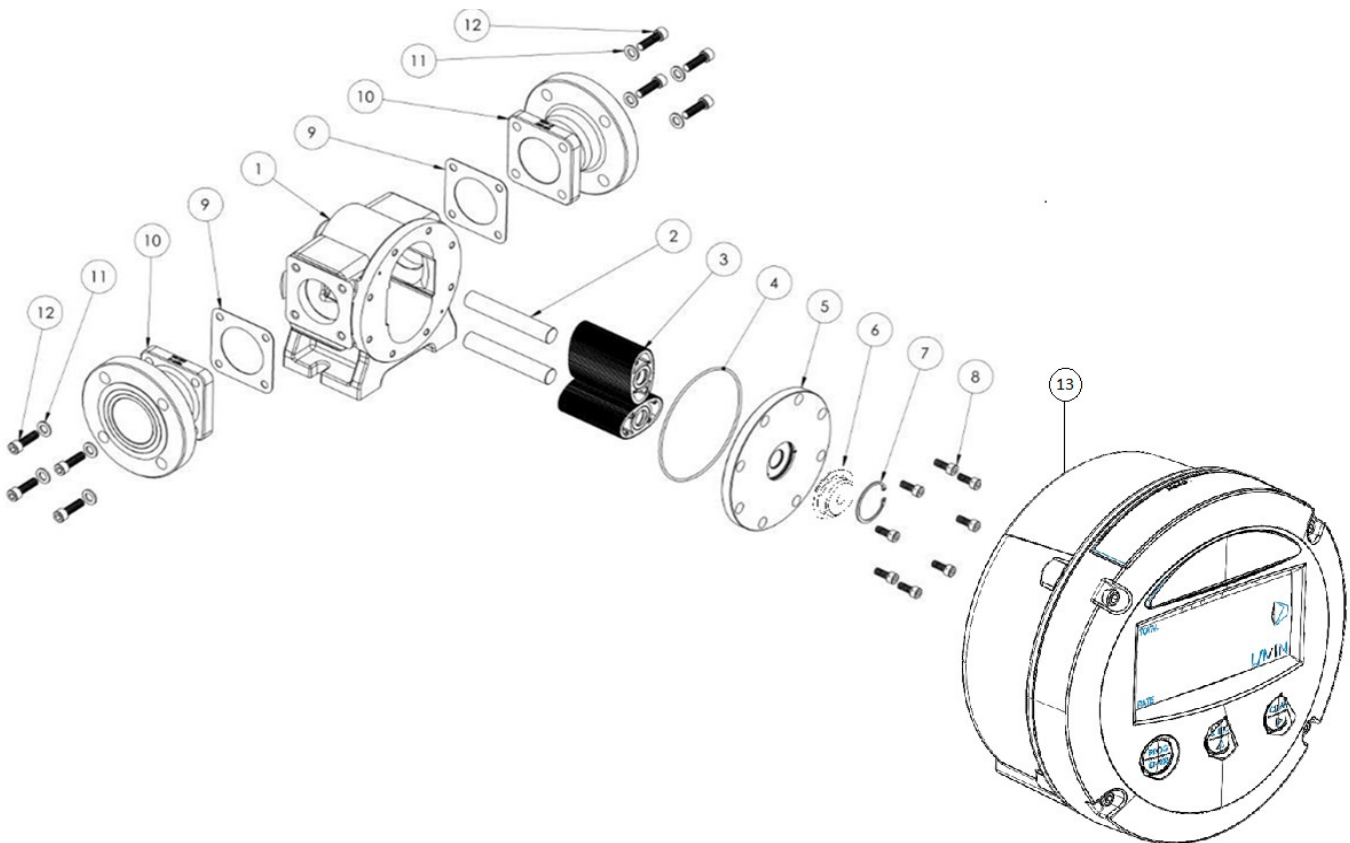

METER COMPONENTS	ITEM NO	METER COMPONENTS	ITEM NO
METER BODY	1	CIRCLIP	7
ROTOR SHAFTS	2	METER CAP BOLTS	8
ROTORS	3	FLANGE SEALS	9
METER CAP O-RING	4	PROCESS CONNECTION (FLANGED OR THREADED)	10
METER CAP	5	FLANGE WASHERS	11
CAM	6	FLANGE BOLTS	12

## TROUBLESHOOTING GUIDE

Problem	Cause	Remedy
Fluid will not flow through meter	<ul style="list-style-type: none"> <li>a) Foreign matter blocking rotors</li> <li>b) Line strainer blocked</li> <li>c) Damaged rotors</li> <li>d) Meter connections over tightened</li> <li>e) Fluid is too viscous</li> </ul>	<ul style="list-style-type: none"> <li>a) Dismantle meter, clean rotors (strainer must be fitted in line)</li> <li>b) Clean strainer</li> <li>c) Replace rotors (Strainer must be fitted in line)</li> <li>d) Re-adjust connections</li> <li>e) See specifications for maximum viscosity</li> </ul>
Reduced flow through meter	<ul style="list-style-type: none"> <li>a) Strainer is partially blocked</li> <li>b) Fluid is too viscous</li> </ul>	<ul style="list-style-type: none"> <li>a) Clean strainer</li> <li>b) See specifications for maximum viscosity</li> </ul>
Meter reading inaccurate	<ul style="list-style-type: none"> <li>a) Fluid flow rate is too high or too low</li> <li>b) Air in fluid</li> <li>c) Excess wear caused by incorrect installation</li> </ul>	<ul style="list-style-type: none"> <li>a) See specifications for minimum and maximum flow rates</li> <li>b) Bleed air from system</li> <li>c) Check meter body and rotors. Replace as required. Refer to installation instructions</li> </ul>
LCD register not working	<ul style="list-style-type: none"> <li>a) Battery not connected properly</li> <li>b) Battery flat</li> <li>c) Faulty wiring connections</li> <li>d) Faulty LC Display</li> <li>e) Faulty connection from LC Display</li> </ul>	Contact Macnaught

## MAINTAINENCE VIDEOS

Macnaught provides an comprehensive set of 'Maintenance Videos' to assist the end user in all aspects of service and / or repair of the flow meter range.

This web based resource can be accessed by scanning the QR.



## WETTED PARTS

Wetted Parts	MX06P	MX09P - MX12P	MX19P - MX50P		MX75P - MX100P
METER BODY	SS 316	SS 316	SS 316		*
METER CAP	SS 316	SS 316	SS 316		*
ROTORS	SS 316	SS 316	SS 316/PEEK **		*
HIGH VISCOSITY ROTORS	-	SS 316	SS 316		*
ROTOR SHAFTS	SS 316	SS 316	SS 316		*
ROTOR BUSHES	CARBON	CARBON	CARBON		*
O-RINGS	FEP	FEP	FEP		*
Wetted Parts	MX06S	MX09S - MX12S	MX19S - MX25S	MX40S - MX50S	MX75S - MX100S
METER BODY	AL	AL	AL	AL	AL
METER CAP	AL	AL	AL	AL	AL
ROTORS	SS 316	SS 316	SS 316/PEEK **	AL/PEEK **	AL
HIGH VISCOSITY ROTORS	-	SS 316	SS 316	AL	AL
ROTOR SHAFTS	SS 316	SS 316	SS 316	SS 316	SS 316
ROTOR BUSHES	CARBON	CARBON	CARBON	CARBON	CARBON
O-RINGS	FEP	FEP	FEP	FEP	FEP

\* Currently Unavailable

\*\* SS 316 and AL rotors are assembled with carbon bushes. PEEK rotors do not have carbon bushes.

FEP - *PTFE Encapsulated*

SS 316 - *Stainless Steel 316*

AL - *Aluminium Alloy*

PEEK - *Polyether ether ketone*

## SPARE PARTS KITS

Category “P”	ROTOR KIT			SEAL KIT
	High Temperature SS 316	High Viscosity SS 316 (High Temp)	PEEK	
MX06P	MXS-06P-HTROTOR	-	-	MXS-06P-SEAL
MX09P	MXS-09P-HTROTOR	MXS-09P-HVROTOR	-	MXS-09P-SEAL
MX12P	MXS-12P-HTROTOR	MXS-12P-HVROTOR	-	MXS-12P-SEAL
MX19P	MXS-19P-HTROTOR	MXS-19P-HVROTOR	MXS-19P-PROTOR	MXS-19P-SEAL
MX25P	MXS-25P-HTROTOR	MXS-25P-HVROTOR	MXS-25P-PROTOR	MXS-25P-SEAL
MX40P	MXS-40P-HTROTOR	MXS-40P-HVROTOR	MXS-40P-PROTOR	MXS-40P-SEAL
MX50P	MXS-50P-HTROTOR	MXS-50P-HVROTOR	MXS-50P-PROTOR	MXS-50P-SEAL
MX75P	-	-	-	-
MX100P	-	-	-	-

Category “S”	ROTOR KIT			SEAL KIT
	Standard	High Viscosity	PEEK	
MX06S	MXS-06S-ROTOR	-	-	MXS-06S-SEAL
MX09S	MXS-09S-ROTOR	MXS-09S-HVROTOR	-	MXS-09S-SEAL
MX12S	MXS-12S-ROTOR	MXS-12S-HVROTOR	-	MXS-12S-SEAL
MX19S	MXS-19S-ROTOR	MXS-19S-HVROTOR	MXS-19S-PROTOR	MXS-19S-SEAL
MX25S	MXS-25S-ROTOR	MXS-25S-HVROTOR	MXS-25S-PROTOR	MXS-25S-SEAL
MX40S	MXS-40S-ROTOR	MXS-40S-HVROTOR	MXS-40S-PROTOR	MXS-40S-SEAL
MX50S	MXS-50S-ROTOR	MXS-50S-HVROTOR	MXS-50S-PROTOR	MXS-50S-SEAL
MX75S	MXS-75S-ROTOR	MXS-75S-HVROTOR	-	MXS-75S-SEAL
MX100S	MXS-100S-ROTOR	MXS-100S-HVROTOR	-	MXS-100S-SEAL

- Currently Unavailable



Note !

To check for more service kits, Contact Macnaught.



Note !

Contact Macnaught for available display kits

# PRESSURE DROP v VISCOSITY

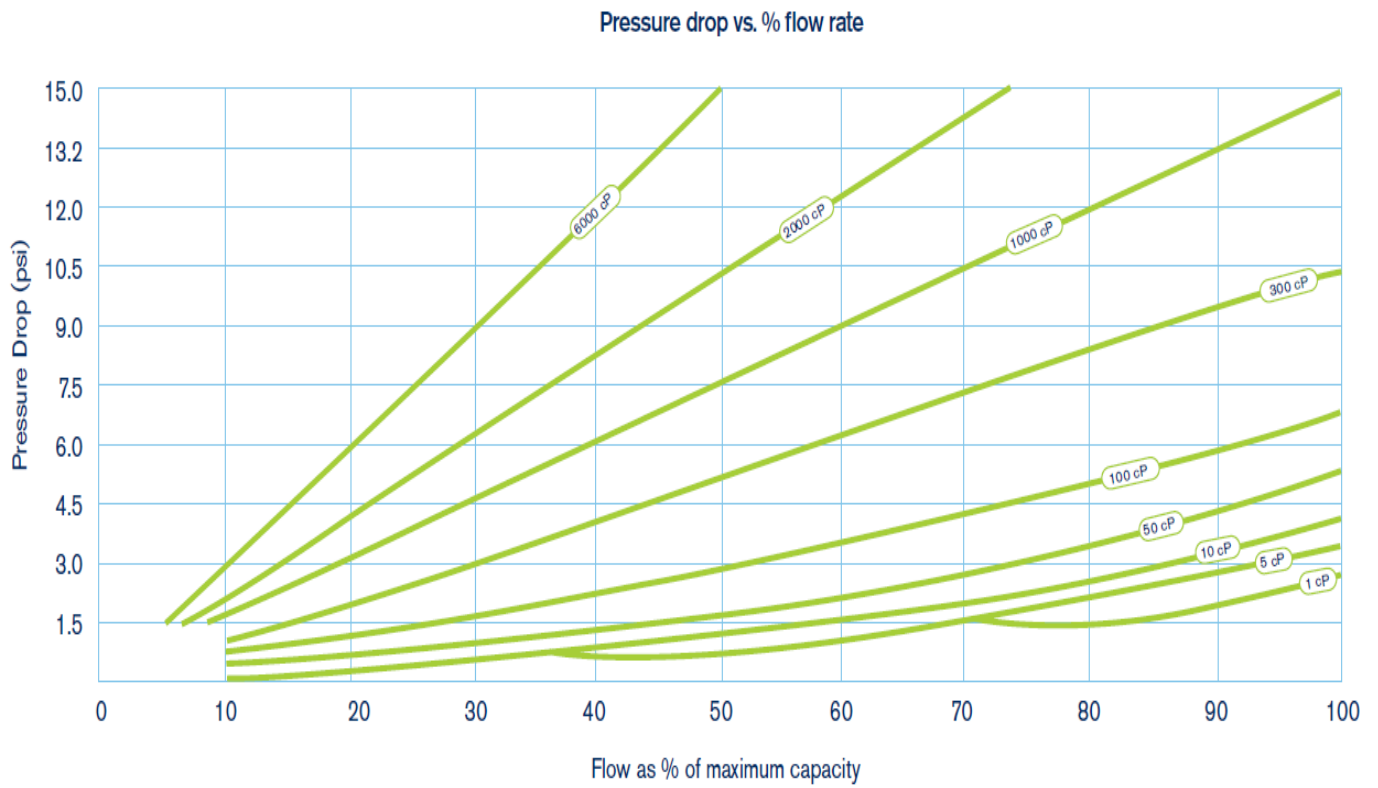
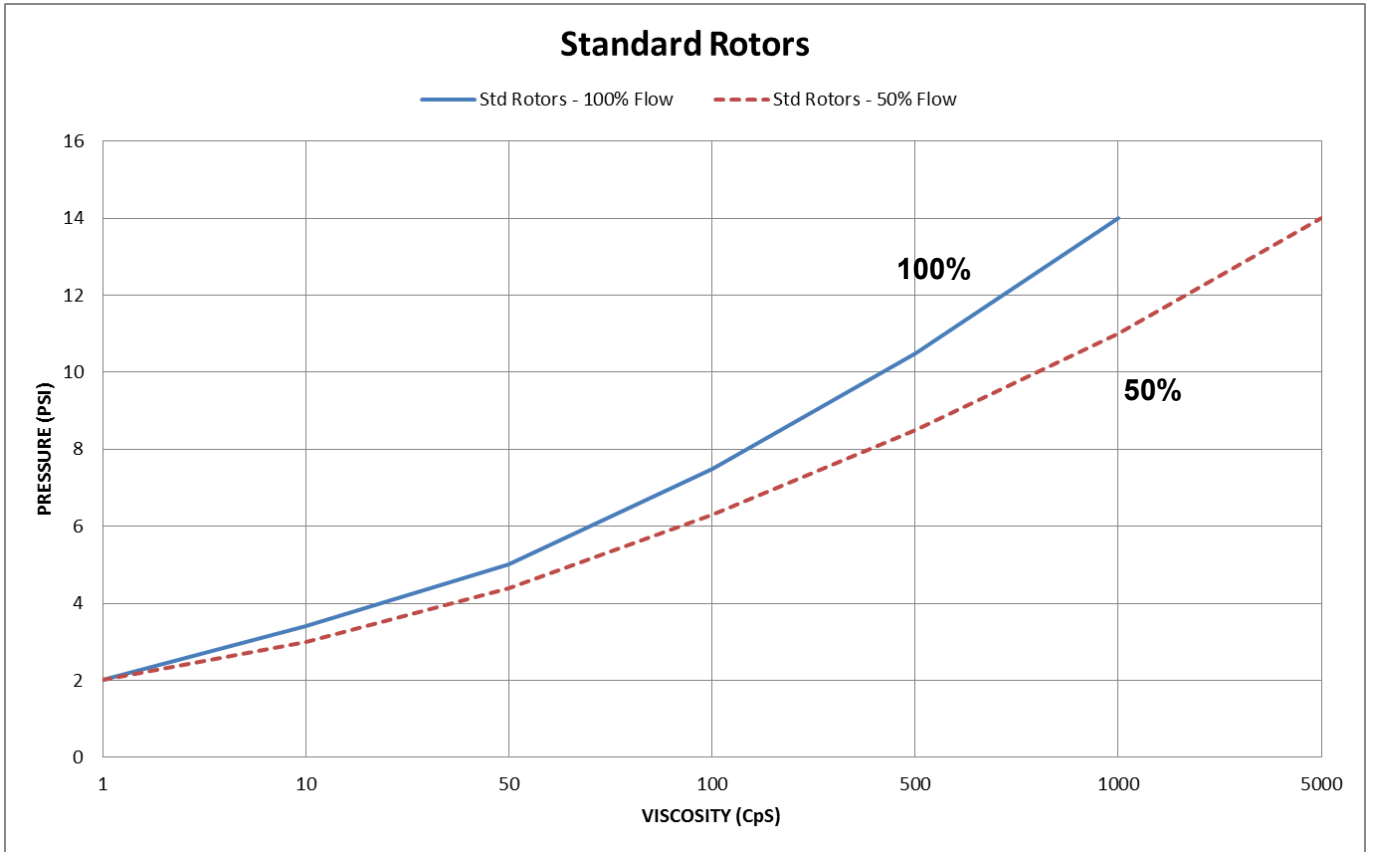

## DIMENSIONS

## Flow Meters MX06 - MX50

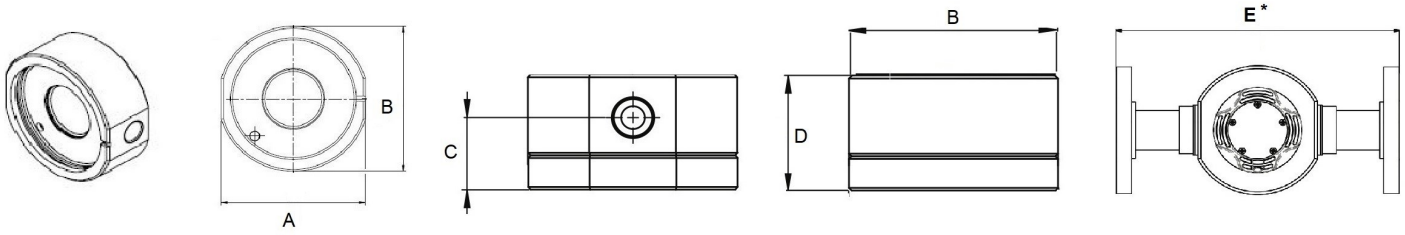

Flow meter	A (mm)	B (mm)	C (mm)	D (mm)	E (mm)
MX06	71	74	25	42	N/A
MX09	71	74	25	42	N/A
MX12	81	87	28	49	N/A
MX19	100	112	37	62	N/A
MX25	100	112	45	75	240*
MX40	120	137	61	120	240*
MX50	140	153	72	123	264*



Note !

**FLANGE TYPES:** ANSI flanges 150 # and DIN PN 16 flanges are raised faced (RF) while JIS 10k flanges are flat faced (FF) by default. Contact Macnaught if a different configuration is required.

## DIMENSIONS

## Flow Meters MX75

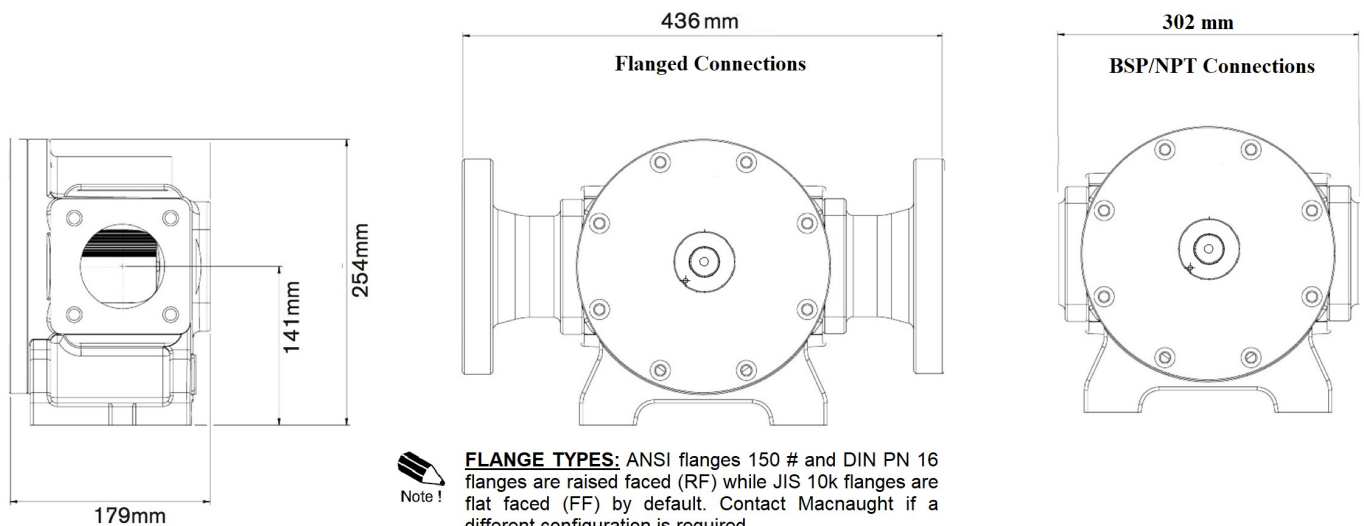

Note !

**FLANGE TYPES:** ANSI flanges 150 # and DIN PN 16 flanges are raised faced (RF) while JIS 10k flanges are flat faced (FF) by default. Contact Macnaught if a different configuration is required.

## DIMENSIONS

## Flow Meters MX100

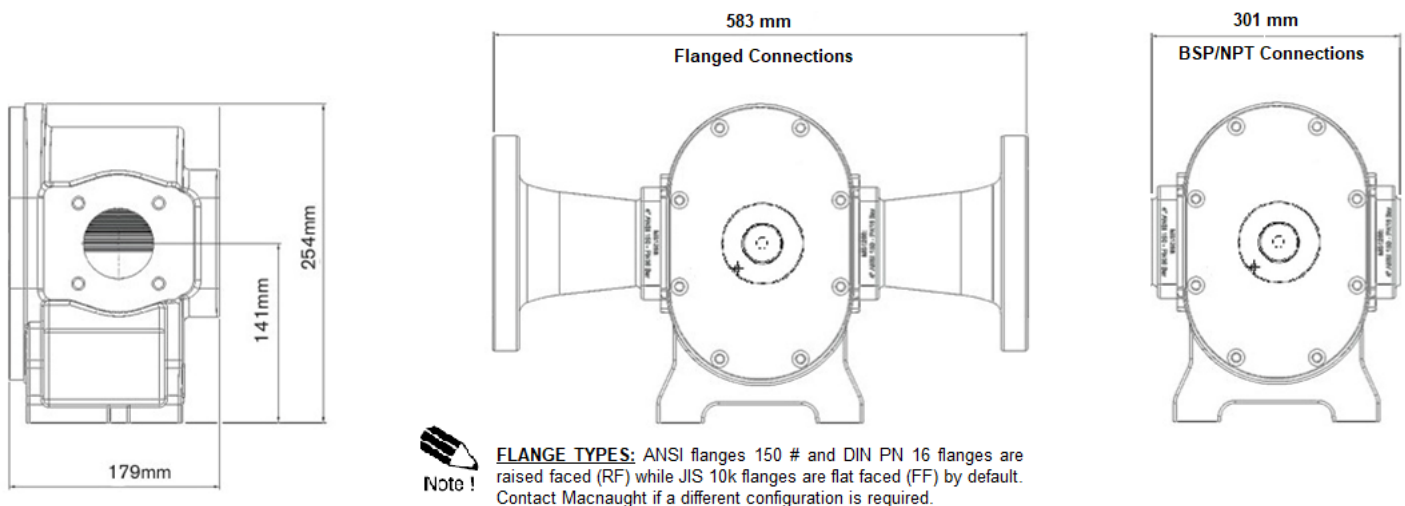

Note !

**FLANGE TYPES:** ANSI flanges 150 # and DIN PN 16 flanges are raised faced (RF) while JIS 10k flanges are flat faced (FF) by default. Contact Macnaught if a different configuration is required.



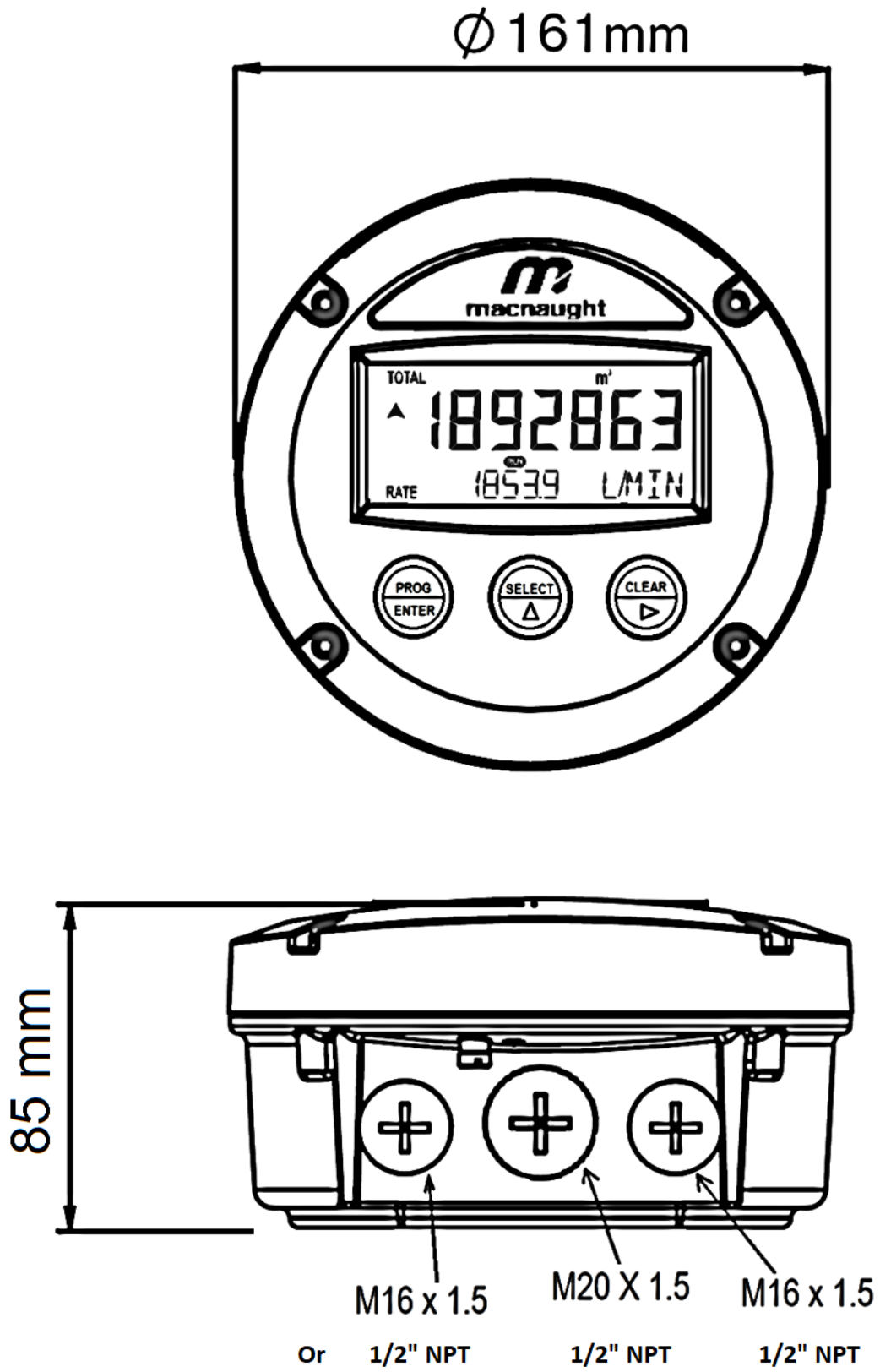

## WALL MOUNT ADAPTOR (MX06 - MX25)

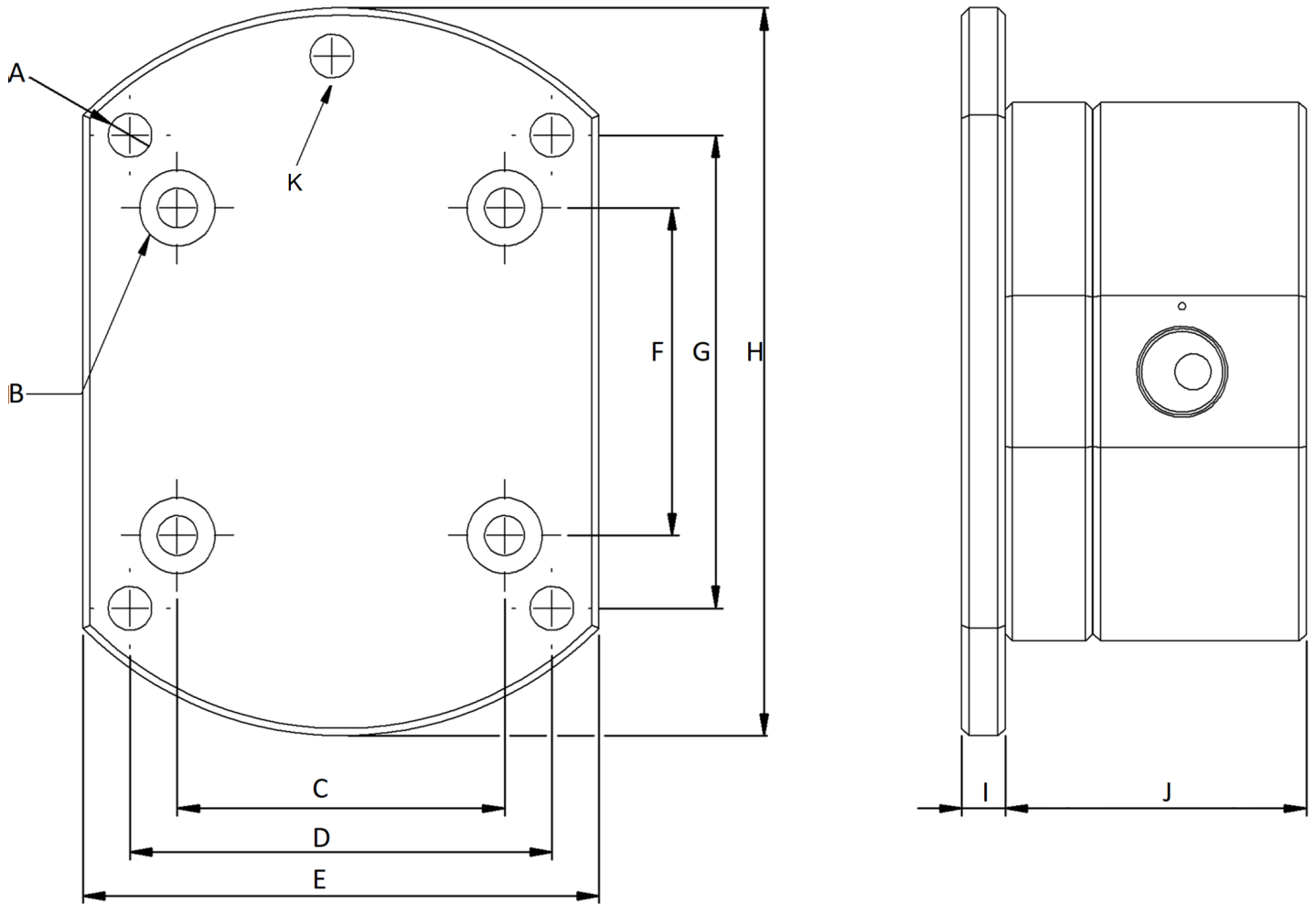

Meters	A (Ø mm)	B (Ø mm)	C (mm)	D (mm)	E (mm)	F (mm)	G (mm)	H (Ø mm)	I (mm)	J (mm)	K (Ø mm)
MX06 - MX09	6	5.5	45	58	71	45	65	100	6	42	M5x0.8
MX12	6	5.5	47	69	81	47	73	113	6	49	M5x0.8
MX19	7	6.6	61	85	100	61	95	143	6	62	M6x1.0
MX25	7	6.6	61	85	100	61	95	143	6	75	M6x1.0

A Wall Mount Holes (4)

B SS Countersunk screws to be supplied with the wall mount bracket  
 5 mm in diameter and 16 mm in length for MX06 - MX12 meters  
 6 mm in diameter and 20 mm in length for MX19 - MX25 meters

K Earthing Point



Note !

## WALL MOUNT THREAD POSITION ON FLOWMETER'S CAP (MX06 - MX50)

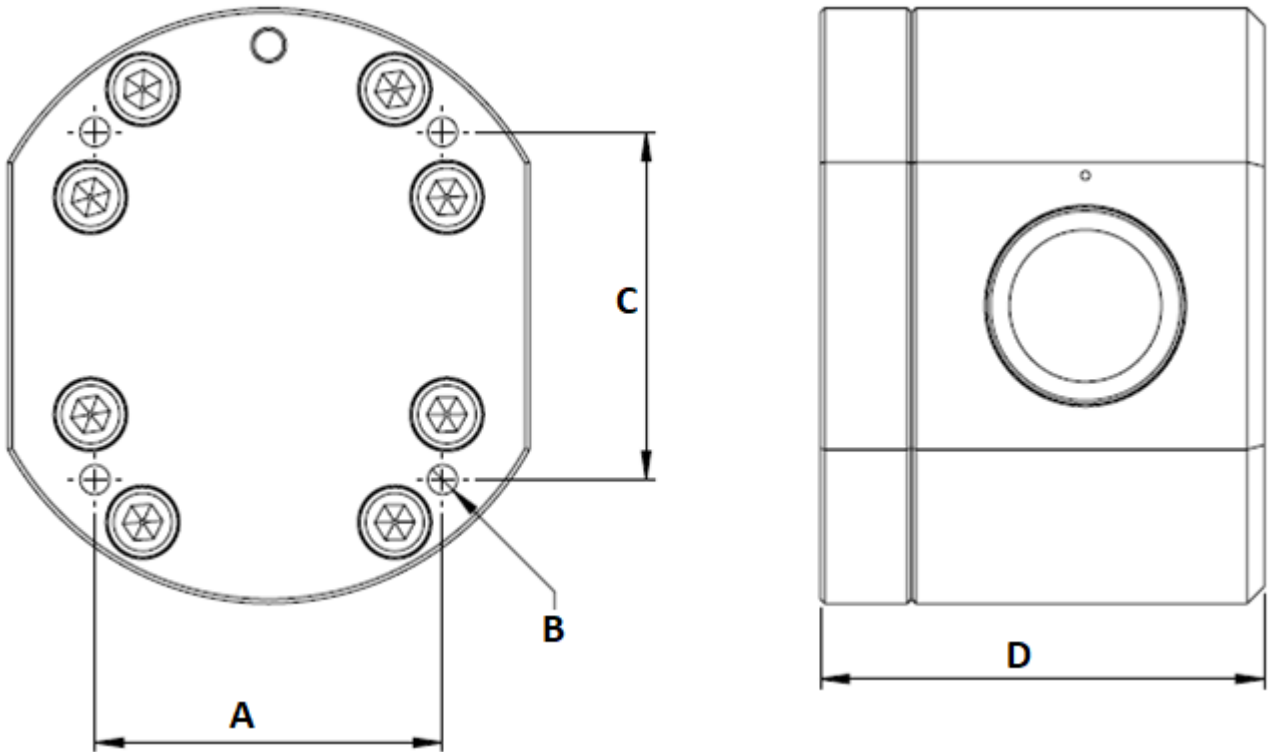

Meters	A	B	C	D
<b>MX06</b>	45	M5 x 0.80	45	42
<b>MX09</b>	45	M5 x 0.80	45	42
<b>MX12</b>	47	M5 x 0.80	47	49
<b>MX19</b>	61	M6 x 1.00	61	62
<b>MX25</b>	61	M6 x 1.00	61	75
<b>MX40</b>	80	M8 x 1.25	80	102
<b>MX50</b>	80	M8 x 1.25	100	123



**B** Mounting Holes x 4  
Earthing Points x 4 (Any of them can be used)

## EU Declaration of Conformity



We: Macnaught Pty Ltd Of:  
41-49 Henderson St  
Turrella NSW 2205  
AUSTRALIA

**Declare that:**

Macnaught Flow Meters prefixed MX, F, CR, M (MH) or S, in accordance with the following Directive; 2006/42/EC Machinery Directive (and its amending directives), have been designed and manufactured to the following specifications; **EN ISO 12100-1:2010 Safety of Machinery**

**Declare that:**

Macnaught Flow Meters prefixed MX, F, CR, M (MH) or S with flange nominal bores sizes up to 4", comply with the requirements of the Pressure Equipment Directive (PED) - 2014/68/EU under the definition of Pressure accessory, designed and manufactured in accordance with the Sound Engineering Practice, based on the classification below:

Article 4, Paragraph 3; Chart 9 Piping intended for Liquids Group II: *Sound Engineering Practice* without restrictions

Article 4, Paragraph 3; Chart 8 Piping Intended for Liquids Group I: *Sound Engineering Practice* **with the following restrictions**

Port nominal size	Max Pressure rating for Group I Liquids
1-1/2" (40mm)	725psi
2" (50mm)	580 psi

**Declare that:**

Macnaught Flow Meter accessories prefixed MXD family of pulse boards (Macnaught designed) as fitted to the Flow Meters, in accordance with the following Electromagnetic Compatibility – Directive 2014/30/EU (and its amending directives), have been designed and manufactured to the following specifications; **EN61326-1:2013 Electromagnetic Compatibility – Electrical equipment for measurement, control and laboratory use**, industrial electromagnetic environment.

**Declare that:**

Macnaught Flow Meter accessories prefixed DR, ER or PR as fitted to the Flow Meters or remotely mounted, have been designed and manufactured to the following specifications; **EN61326-1:2006 Electromagnetic Compatibility – Electrical equipment for measurement, control and laboratory use**, industrial electromagnetic environment. After due consideration, it has been assessed that the technical requirements of EN61326-1:2013 have not changed from EN61326-1:2006 for industrial electromagnetic environments, and is therefore in conformance with the following Electromagnetic Compatibility – Directive 2014/30/EU (and its amending directives).

**Declare that:**

Macnaught Flow Meters prefixed MX, F, CR, M (MH) or S with flange nominal bores sizes up to 4" are manufactured in accordance with the following Directive; **RoHS Directive 2011/65/EU** and amendments **(EU) 2015/863** and **(EU) 2017/2102**.

I hereby declare that the equipment named above has been designed to comply with the relevant sections of the above referenced specifications. The product complies with all essential requirements of the Directives. This declaration is no longer valid if the unit is modified without our agreement.

Name: Marco Uccellani  
Position: Engineering Manager  
Date: 06/11/2020  
Done at: Macnaught Pty Ltd; 41-49 Henderson St; Turrella NSW 2205; Australia

Signature:





## EU - Declaration of Conformity Directive 2014/34/EU (ATEX)

Macnaught Pty Limited, 41-49 Henderson St, Turrella NSW 2205 Sydney Australia, herewith confirms that the products listed below comply with the basic requirements of the relevant directives concerning design, construction, health, safety and marketing. This declaration is no longer valid if the unit is modified without agreement from Macnaught.

### Type of unit

MX Series Flow Meters

### Description of the unit

Oval gears flow meter

### Product Classification

Equipment Group	II
Equipment Category	2
Explosive Atmosphere	G

### Explosion Protection

Fulfilling of non-electrical explosion protection requirements for the oval gear flow meter.

The evaluation of ignition hazards by means of a risk analysis shows that there is no own potential source of ignition during normal and expected abnormal operation. The products mentioned in this document comply with the requirements of harmonised standards BS EN ISO 80079-36 and BS EN ISO 80079-37 and can be used in hazardous areas as Category 2 devices.

Equipment	Harmonised Standard Applied	Notified Body	Notification of Receipt of Technical Documentation Number	Marking
Non-electrical part	BS EN ISO 80079-36	SIRA 0518	SIRA 15XT063	II 2 G k TX*
	BS EN ISO 80079-37			* See Manual
Electronic Sensor (MX7)	Please refer to Manufacturer Declaration of Conformity			
Electronic Sensor (MX7N)	Please refer to Manufacturer Declaration of Conformity			
Electronic Sensor (MX8)	Please refer to Manufacturer Declaration of Conformity			
MXD Ex-ia Register/Display Module*	BS EN ISO 80079-36	SIRA 0518	SIRA 15XT063	II 2 G k TX*
	BS EN ISO 80079-37 REFER TO MACNAUGHT INSTRUCTION MANUAL			* See Manual

\*Applicable Product Part No# MXD-Fx-0M, MXD-Fx-1M, MXD-Gx-0M, MXD-Gx-1M, MXD-Hx-0M, MXD-Hx-1M, MXD-Fx-0N, MXD-Fx-1N, MXD-Gx-0N, MXD-Gx-1N, MXD-Hx-0N, MXD-Hx-1N.

SIRA: CSA Group Testing UK Ltd - Unit 6 Hawarden Industrial Park Hawarden, CH5 3US, United Kingdom

  
Minh Tran, Head of Manufacturing

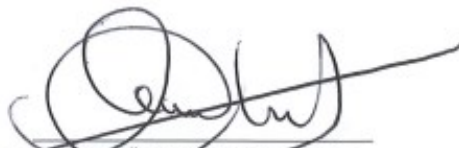
  
Marco Cellani, Engineering Manager

## Declaration of Conformity

### **MX1R-IS module – Reed switch sensor board** Veghel, February 2022

We, Fluidwell BV, declare on behalf of Macnaught Pty Ltd, that the MX1R-IS module – Reed switch sensor board for F-Series indicators or equivalent equipment – complies with the requirements for "Simple Apparatus" per EN 60079-11:2021.

The MX1R-IS module is designed and will operate conform the following applicable European Directives and Harmonised Standards, when installed according to the related Component Integration Guide\*.

EMC Directive	2014/30/EU	EN 61000-6-2:2005; EN 61000-6-3: 2007 /A1:2011; EN 61326-1:2013
RoHS Directive	2011/65/EU (incl. current amendments)	EN 50581:2012 EN IEC 63000:2018

#### **For Intrinsically Safe applications**

ATEX Directive	2014/34/EU	EN IEC 60079-0:2018 EN 60079-11:2012
	Protective system	II 1 G Ex ia IIC Ga

\* Component Integration Guide: FW\_MX1R-IS\_CIG\_v0101-xx\_EN (*xx = minor version number*)

Indicators other than the Fluidwell F0- or F1-Series to be used in conjunction with the MX1R-IS module shall be subject to additional functional, regulatory and safety evaluation.

I. Meij, Manager Technology



**Fluidwell BV** – P.O.Box 6, 5460 AA, Veghel, The Netherlands – Voltaweg 23, 5466 AZ, Veghel, The Netherlands  
Fluidwell BV is ISO9001 certified by DEKRA Certification BV, Meander 1051, 6825 MJ, Arnhem, The Netherlands.

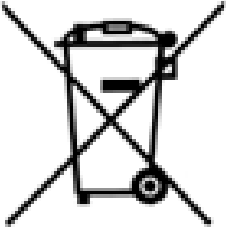

The WEEE Directive requires the recycling of waste electrical and electronic equipment in the European Union.

Whilst the WEEE Directive does not apply to some of Macnaught's products, we support its policy and ask you to be aware of how to dispose of this product.

The crossed out wheelie bin symbol illustrated and found on our products signifies that this product should not be disposed of in general waste or landfill.

Please contact your local dealer national distributor or Macnaught Technical Services for information on product disposal.



**Built to last since 1948**

Macnaught USA  
614 S. Ware Blvd  
Tampa, FL 33619

(813) 628-5506  
MacnaughtUSA.com

**Note:**

This product should be disposed of according to all applicable local and national government environment regulations and

