

Internationally Approved
EN 15267 Certified



Continuous Emissions Monitoring
and Process Control

Sulphuric Acid Production

Continuous Emissions Monitoring and Process Control

Sulphuric Acid Production

The process control of a sulphuric acid plant needs good and reliable detection of gas phase SO₂. To measure SO₂ is a challenge due to the corrosive environment and high concentration of SO₂.

Several places in the process needs to be monitored and to transport the sample gas is difficult. A large dynamic range is needed as the SO₂ concentration can vary between 15% volume and a few mg/m³.

Most systems installed need a lot of maintenance, sometimes as often as every day.

The OPSIS DOAS system is different and provides sulphuric acid plants with an accurate analyser that can measure in temperatures up to 1000°C and with a maximum pressure of 1 Bar (G).

The system operates with a minimum of maintenance. A typical service interval with an OPSIS system is 3 to 6 months. The OPSIS DOAS system is a non-contact method, using an optical measurement path that operates across a duct. The optical light is transported in an optical fibre to the analyser and one analyser can operate several paths.

Besides the measurements of SO₂, additional gases such as SO₃, H₂O and O₂ can be measured.

RETURN OF INVESTMENT

The cost of investing in an OPSIS DOAS system, to measure SO₂ and other gases, is small compared to the amount of money that can be saved by having better control of the process. The cost of the OPSIS DOAS system is also small compared to the amount of money that are spent on maintaining old systems based on extractive techniques.

TEST AND APPROVALS

The OPSIS system has been tested and approved by a number of internationally recognized institutes and authorities. The system meets the European directive for power plants and is approved by German TÜV, British MCERTS and U.S. EPA. Full details are available on request.

OPSIS PRODUCT PORTFOLIO

OPSIS has a full product portfolio for measurements of gases in a sulphuric acid production plant. It includes systems for continuous emissions monitoring, process control as well as for air quality monitoring. The total solution also includes highly skilled service and support.

For further information, please visit www.opsis.se.

A schematic drawing of a sulphuric acid production plant including the SO₂ and NO_x measurement points of the OPSIS monitoring system.

OPSIS Monitoring Paths

1. SO₂: 0–20% Vol.
2. SO₂: 0–20% Vol.
3. SO₂: 0–2% Vol.
4. SO₂: 0–2500 ppm
5. NO: 0–500 ppm
NO₂: 0–100 ppm
SO₂: 0–1000 ppm
6. SO₂: 0–20% Vol.

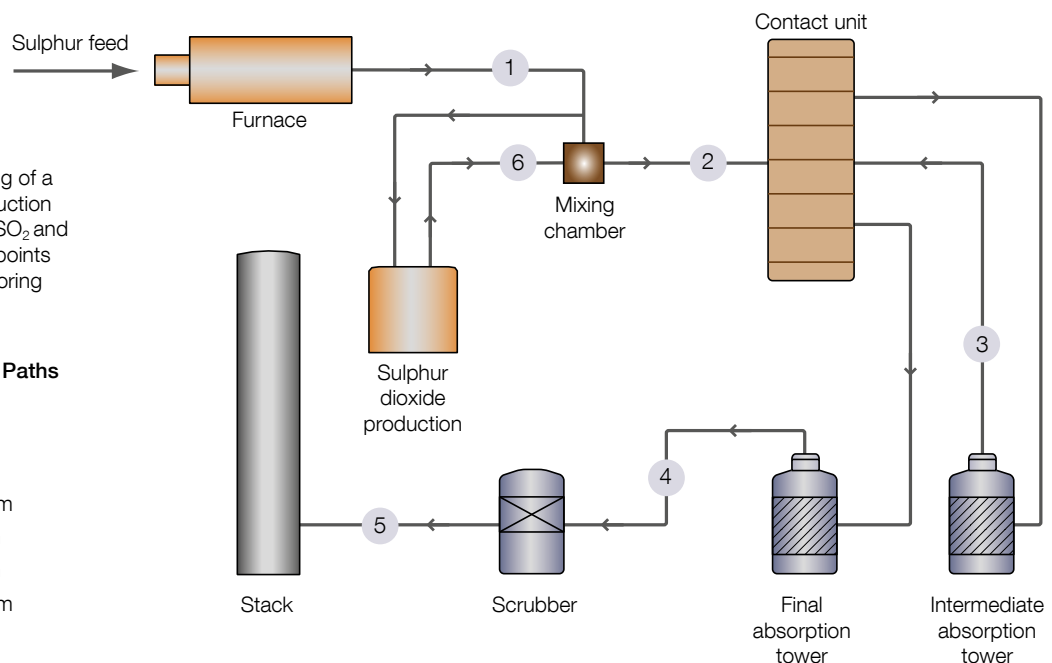

SYSTEM OVERVIEW

An OPSIS system layout for monitoring in a sulphuric acid production plant

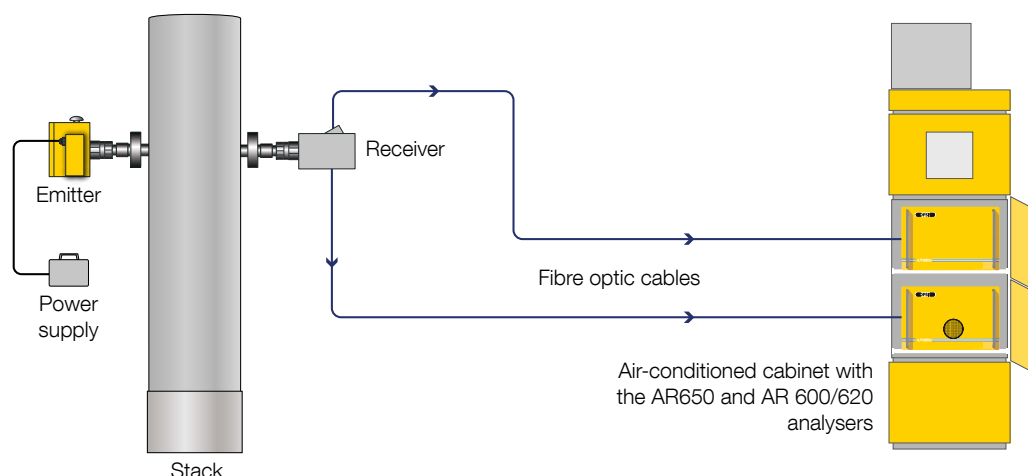

QAL 1 CERTIFICATION:
 BEST PERFORMANCE
 LONGEST CALIBRATION INTERVAL

PERFORMANCE DATA

(typical data which may vary depending on application)

Compound	Max. measurement range (1 m path) ⁽¹⁾	Lowest measurement range according to EN 15267	Min. detectable quantities (monitoring path 1 m, measurement time 30 sec.)
UV/IR DOAS Analyser Models AR600 / AR602Z / AR602Z/Hg / AR602Z/N / AR602Z/NHg / AR620			
SO ₂ emission	0–5000 mg/m ³	0–75 mg/m ³	0.5 mg/m ³
SO ₂ process	0–100% Vol.	—	0.1% Vol.
SO ₃ ⁽²⁾	0–1000 g/m ³	—	0.3 g/m ³
NO ⁽³⁾	0–2000 mg/m ³	0–150 mg/m ³	0.5 mg/m ³
NO ₂	0–2000 mg/m ³	0–20 mg/m ³	0.5 mg/m ³
H ₂ O	0–100% Vol.	0–30% Vol.	0.1% Vol.
Hg ⁰	0–1000 µg/m ³	0–45 µg/m ³	0.5 µg/m ³
FTIR DOAS Analyser Models AR650 / AR650/N			
SO ₂	0–1000 g/m ³	—	30 mg/m ³
SO ₃	0–1000 g/m ³	—	30 mg/m ³
CO	0–10000 mg/m ³	0–75 mg/m ³	2 mg/m ³
H ₂ O	0–100% Vol.	0–30% Vol.	0.1% Vol.
CO ₂	0–100% Vol.	0–20% Vol.	0.1% Vol.
CH ₄	0–10000 mg/m ³	0–20 mg/m ³	0.5 mg/m ³
HF	0–1000 mg/m ³	0–1.5 mg/m ³	0.1 mg/m ³
HCl	0–5000 mg/m ³	0–15 mg/m ³	0.5 mg/m ³
LD500 Laser Diode Gas Analyser			
CO	0–100% Vol.	—	0.1% Vol.
CO ₂	0–100% Vol.	—	0.1% Vol.
H ₂ O	0–100% Vol.	—	0.1% Vol.
H ₂ S	0–100% Vol.	—	0.1% Vol.
O ₂	0–21%	—	0.1% Vol.
Temperature	0–1400°C	—	10°C

⁽¹⁾ This data refers to a light path of 1 m. For longer paths the maximum range is proportionally smaller. Products are available to create shorter paths in very wide stacks.

⁽²⁾ Maximum SO₃ concentration 500 mg/m³ × m.

⁽³⁾ Maximum SO₂ concentration 5 g/m³ × m.

• Recommended monitoring path length: 1 to 5 m.

• After wet scrubbers or when the particulate concentration is high, the monitoring path length may have to be reduced.

- For span and zero drift, please refer to QAL1 documents.
 - Linearity error (of measurement range, better than): ±1%.
 - Max. length of fibre optic cable: please refer to product sheet P9 and P16
- Besides the compounds above, the OPSIS system monitors the following gases: hydrogen bromide (HBr), bromine (Br₂), iodine (I₂), hydrogen cyanide (HCN), phosgene (COCl₂), and others.

Continuous Emissions Monitoring and Process Control by OPSIS

Combines the benefits of UV/FTIR DOAS and TDL technology

Best performance according to QAL 1 certification

Longest calibration interval according to QAL 1 certification

Automatic QAL 3 check as option

No sampling required, non-contact measurement system

One analyser can operate several monitoring paths

Operates with a minimum of maintenance

Low energy consumption

Gas calibration only once per year

Internationally approved

Thousands of systems installed worldwide

Serviced by highly skilled service network

A6
2015 04

Please contact your OPSIS supplier to discuss your particular system requirements, including the compounds you wish to monitor. Separate product and other industrial application sheets are available. Specifications subject to change without notice.

OPSIS AB