

Internationally Approved
EN 15267 Certified



Continuous Emissions Monitoring
and Process Control

Waste to Energy Plants

Continuous Emissions Monitoring and Process Control Waste to Energy Plants

Process control and emission monitoring in a waste to energy plant is a challenge. A large number of gaseous components need to be measured with high accuracy. Almost 100% uptime is required and the monitoring system needs to be easy to maintain and fast to calibrate.

The OPSIS system is different compared to other systems on the market and provides the waste to energy plant with an accurate analyser that will operate with a minimum of maintenance.

The OPSIS system is based on a non-contact DOAS/FTIR method, using an optical path that can operate across the duct. The optical light is transported in an optical fibre to the analyser and one analyser can operate several paths.

A single OPSIS system will measure all relevant gas components such as NO_x, SO₂, CO, CO₂, H₂O, HCl, HF, NH₃, CH₄ and Hg.

RETURN OF INVESTMENT

The cost of investing in an OPSIS system is small compared to the amount of money that is spent on maintaining old and complex extractive systems.

The OPSIS system has low cost of ownership based on few moving parts, long intervals between calibrations, easy operation and low energy consumption.

TEST AND APPROVALS

The OPSIS system has been tested and approved by a number of internationally recognized institutes and authorities. The system meets the European directive for waste and is approved by German TÜV and British MCERTS. Full details are available on request.

OPSIS PRODUCT PORTFOLIO

OPSIS has a full product portfolio for measurements of gases in a range of applications. It includes complete CEM systems including reporting, process analysers for raw gas measurements, TDL analysers for NH₃, HCl, and O₂, oxygen analysers, compact analysers based on dilution extractive and Hg analysers.

For further information, please visit www.opsis.se.

QAL 1 CERTIFICATION:
BEST PERFORMANCE
LONGEST CALIBRATION INTERVAL

OPSIS monitoring system is an effective tool for controlling the different emissions and process control spots in a waste incinerator

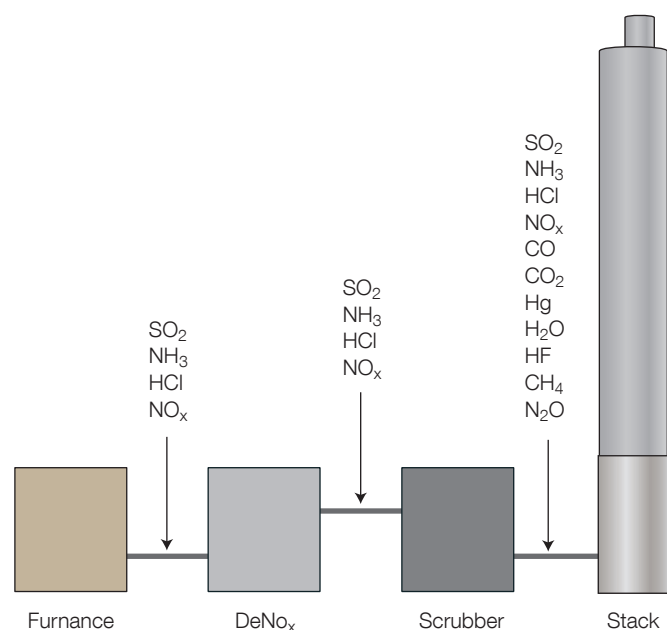

SYSTEM OVERVIEW

An OPSIS system layout for emissions monitoring and process control in a waste incineration plant.

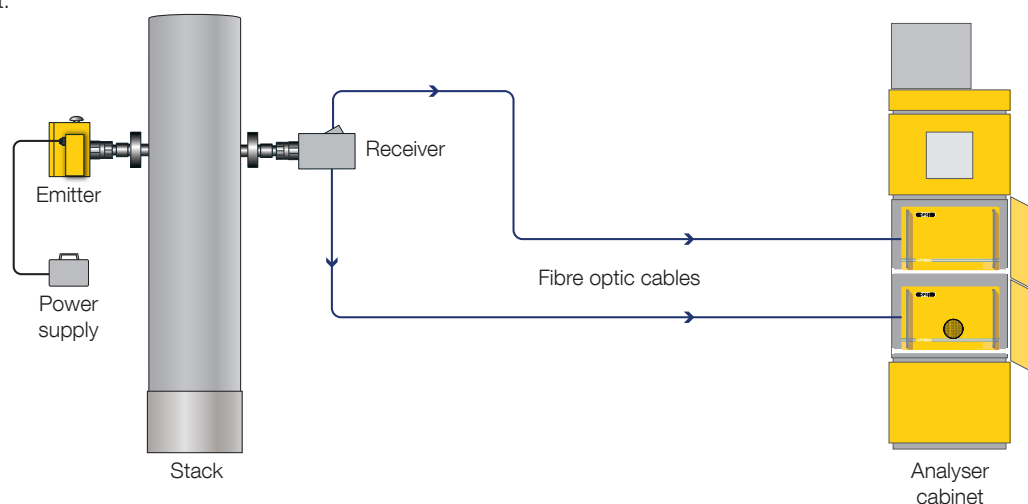

PERFORMANCE DATA

(typical data which may vary depending on application)

Compound	Max. measurement range (1 m path) ⁽¹⁾	Lowest measurement range according to EN 15267	Min. detectable quantities (monitoring path 1 m, measurement time 30 sec.)
UV/IR DOAS Analyser Models AR600 / AR602Z / AR602Z/Hg / AR602Z/N / AR602Z/NHg / AR620			
NO ⁽²⁾	0-2000 mg/m ³	0-150 mg/m ³	0.5 mg/m ³
NO ₂	0-2000 mg/m ³	0-20 mg/m ³	0.5 mg/m ³
SO ₂	0-5000 mg/m ³	0-75 mg/m ³	0.5 mg/m ³
NH ₃ ⁽³⁾	0-1000 mg/m ³	0-10 mg/m ³	0.5 mg/m ³
Hg ⁰	0-1000 µg/m ³	0-45 µg/m ³	0.5 µg/m ³
Hg ^{tot}	0-1000 µg/m ³	0-45 µg/m ³	0.5 µg/m ³
H ₂ O	0-100% Vol.	0-30% Vol.	0.1% Vol.
Benzene	0-1000 mg/m ³	—	1 mg/m ³
Br ₂	0-10000 mg/m ³	—	5 mg/m ³
I ₂	0-10000 mg/m ³	—	5 mg/m ³
FTIR DOAS Analyser Models AR650 / AR650/N			
HCl	0-5000 mg/m ³	0-15 mg/m ³	0.5 mg/m ³
CO	0-10000 mg/m ³	0-75 mg/m ³	2 mg/m ³
H ₂ O	0-100% Vol.	0-30% Vol.	0.1% Vol.
HF	0-1000 mg/m ³	0-1.5 mg/m ³	0.1 mg/m ³
NH ₃	0-1000 mg/m ³	-	2 mg/m ³
N ₂ O ⁽⁴⁾	0-10000 mg/m ³	0-500 mg/m ³	5 mg/m ³
CH ₄	0-10000 mg/m ³	0-20 mg/m ³	0.5 mg/m ³
CO ₂	0-100% Vol.	0-20% Vol.	0.1% Vol.
LD500 Laser Diode Gas Analyser			
HCl	0-5000 mg/m ³	—	0.5 mg/m ³
CO	0-100% Vol.	—	0.1% Vol.
H ₂ O	0-100% Vol.	—	0.1% Vol.
HF	0-5000 mg/m ³	—	0.1 mg/m ³
NH ₃	0-5000 mg/m ³	—	0.5 mg/m ³
CO ₂	0-100% Vol.	—	0.1% Vol.
O ₂	0-21% Vol.	—	0.1% Vol.
CH ₄	0-10000 mg/m ³	—	0.5 mg/m ³
Temperature	0-1400°C	—	5°C

⁽¹⁾ This data refers to a light path of 1 m. For longer paths, the maximum range is proportionally smaller. Products are available to create shorter paths in very wide stacks.

⁽²⁾ Maximum SO₂ concentration: 5 g/m³ x m.

⁽³⁾ Maximum SO₂ concentration: 500 mg/m³ x m.

⁽⁴⁾ Detection limit of 1 mg/m³ is optional with hardware upgrade.

- Recommended monitoring path length: 1 to 5 m.
- After wet scrubbers or when particulate concentration averaged over 1 m is higher than 5 g/m³, the monitoring path length may have to be reduced.
- Accuracy is better than 2% of measured value or equal to the detection limit (whichever is the greater).
- For span and zero drift, please refer to QAL1 documents.
- Linearity error (of measurement range, better than): ±1%.
- Max. length of fibre optic cable: please refer to product sheet P9 and P16.

Continuous Emissions Monitoring and Process Control by OPSIS

One system for all components including Hg
Combines the benefits of UV/FTIR DOAS and TDL technology
Best performance according to QAL 1 certification
Longest calibration interval according to QAL 1 certification
Automatic QAL 3 check as option
No sampling required, non-contact measurement system
Operates with a minimum of maintenance
Low energy consumption
Gas calibration only once per year
Internationally approved
Thousands of systems installed worldwide
Serviced by highly skilled service network

A1
2015 04

Please contact your OPSIS supplier to discuss your particular system requirements, including the compounds you wish to monitor. Separate product and other industrial application sheets are available. Specifications subject to change without notice.