

Thank you for choosing a NIVELCO instrument!

# NIVOSWITCH

R-400, R-400 Ex  
VIBRATING FORK LEVEL SWITCH

## 1. APPLICATION

The NIVOSWITCH R-400 vibrating fork level switches are used for level or flow switching tasks of normal and explosive liquids. Overfill and dry run protection, as well as pump control, are also possible with the NIVOSWITCH vibrating fork level switches in low/high fail-safe operating mode.

## 2. TECHNICAL DATA

### 2.1 GENERAL DATA

R□□-4□□-6 R□□-4□□-□Ex		
Medium pressure	40 bar (580 psi), PP flange: 6 bar (87 psi) see "Temperature diagrams"	
Insertion length	69...3000 mm (0.225...10 ft)	
Material of wetted parts	DIN 1.4571, ECTFE / PFA coating	
Medium temperature	-40...+130 °C (-40...+266 °F) see section 5.1 and 2.6 diagrams	
Ambient temperature	-40...+70 °C (-40...+158 °F) see table in 5.1 and diagrams R□□-4□□-L Ex; R□□-4□□-M and -4□□-K -25...+70 °C (-13...+158 °F)	
Medium-density	≥ 0.7 kg/dm <sup>3</sup>	
Medium viscosity	≤ 10000 mm <sup>2</sup> /s (cSt)	
Response time	When immersed	0.5 sec
	When free	When free: ≤ 1 s see response time diagram
Output mode indication	Bi-color (LED)	
Operation test	Output can be toggled by test magnet	

<sup>(1)</sup> Available max. cable length 30 m (100 ft)

### 2.2 2-WIRE DC, NORMAL AND Ex APPROVED VERSION

Type	R□□-4□□-6 R□□-4□□-8Ex	R□□-4□□-K R□□-4□□-LEx	R□□-4□□-7 R□□-4□□-9Ex
Electrical connection	Connector		3 m (10 ft) <sup>(1)</sup> cable (2 x 0.5 mm <sup>2</sup> [AWG20])
Ingress Protection	IP65	IP67	IP68
Output	DC current change: When free: 9 ± 1 mA; When immersed: 14 ± 1 mA		
Consumption	< 0.5 W		
Power supply (U)	15...29 V DC Provided by the PKK-312-8Ex remote switching unit for the Ex-version		
Setting operation mode	By switch on the remote switching unit (Low fail-safe - "L", High fail-safe - "H")		
Electrical protection	Class III.		
Ex marking (R□□-4□□-□Ex, R□□-4□□-□Ex)	II 1G Ex ia IIC T6...T4 Ga		
Ex marking (R□□-4□□-□Ex)	II 1G Ex ia IIB T6...T4 Ga		
Intrinsic safety data	U <sub>i</sub> = 29 V; I <sub>i</sub> = 100 mA; P <sub>i</sub> = 1.4 W; C <sub>i</sub> = 7 nF; L <sub>i</sub> = 0 mH		U <sub>i</sub> = 29 V; I <sub>i</sub> = 100 mA; P <sub>i</sub> = 1.4 W; C <sub>i</sub> = 15 nF; L <sub>i</sub> = 0 mH
Reference document number	For temperature classes, see section 5.1 rcm4004m060bh_11		

### USER'S MANUAL



Manufacturer:  
**NIVELCO Process Control Co.**  
H-1043 Budapest, Dugonics u. 11.  
Tel.: (36-1) 889-0100 Fax: (36-1) 889-0200  
E-mail: sales@nivelco.com www.nivelco.com

NIVELCO

### 2.3 2-WIRE AC AND 3-WIRE DC VERSIONS

TYPE	2-WIRE AC		3-WIRE DC		
	R□□-4□□-1	R□□-4□□-2	R□□-4□□-3	R□□-4□□-M	R□□-4□□-4
Electrical connection (wire cross section)	Connector	3 m (10 feet) integral cable, 4 x 0.75 mm <sup>2</sup> (AWG18) (max cable length 30 m [100 feet])	Connector		3 m (10 feet) integral cable, 5 x 0.5 mm <sup>2</sup> (AWG20) (max. cable length 30 m [100 feet])
Mechanical protection	IP65	IP68	IP65	IP67	IP68
High/low mode setting (Low fail-safe - "L", High fail-safe - "H")	Determined by the wiring inside the connector		Determined by the wiring	Switch selectable	Connection within connector
Output	2-wire AC, for serial connection		Field selectable, NPN / PNP transistor switch	Field selectable, galvanically isolated PNP/NPN transistor switch	Wire selectable
Output protection	-		Reverse polarity, overcurrent and short-circuit protection		
Supply voltage	20...255 V AC, 50/60 Hz		12...55 V DC		
Consumption	Depending on the load		< 0.6 W		
Voltage drop when switched on	< 10.5 V		< 4.5 V		
Electrical protection	Class I		Class III		
Load current	max. continuous	350 mA AC 13	I <sub>max</sub> = 350 mA DC / U <sub>max</sub> = 55 V DC		
	min. continuous	10 mA / 255 V, 25 mA / 24 V	-		
	max. impulse	1.5 A / 40 ms	-		
Residual current (in switched off state)	< 6 mA		< 100 μA		

## 2.4 ACCESSORIES

- User's manual
- EU-declaration of conformity
- Accessories (sold separately): - Adjustable sliding sleeve (RPH-112-0)
- Warranty Card
- 1x Sealing ring (2 mm [0.079"] thick Klinger Oilit)
- Test magnetic-screwdriver (RPS-101)

## 2.5 ORDER CODES

NIVOSWITCH R □ □ - 4 □ □ - □ \*

TYPE	CODE	PROCESS CONNECTION	CODE	PROBE LENGTH	CODE	OUTPUT	CODE
Tube + plastic (ECTFE / PFA) coated fork	B	1" BSP	M	Short (69 mm [2.7"])	00	2-wire AC + connector	1
Tube + fork: 1.4571	C	1½" BSP	H	Standard (125 mm [4.9"])	01	2-wire AC + cable	2
Tube + highly polished fork	G	1" NPT	P	0.2...3 m (0.66...10 feet)	02...30	3-wire DC + connector	3
Tube + fork: 1.457, without reed sensor <sup>(1)</sup>	E	1½" NPT	N			3-wire DC + cable	4
		DN50 PN16 PP DIN	F			2-wire DC + connector	6
		DN50 PN40 1.4571 DIN	G			2-wire DC + cable	7
		ANSI 2" RF150 PP	A			2-wire DC + connector + Ex	8
		ANSI 2" RF600 1.4571	B			2-wire DC + cable + Ex	9
		JIS 10K 50A PP	J			2-wire DC + M12 connector	K
		JIS 40K 50A 1.4571	K			2-wire DC + M12 connector + Ex	L
		TriClamp 1½"	T			3-wire DC + M12 connector	M
		TriClamp 2"	R				
		DN40 Pipe coupling	D				
		DN50 Pipe coupling	E				

<sup>(1)</sup> Ex version not available

Note: Flanged versions have 1" process connection

\* Ex version with Ex mark

## 2.6 TEMPERATURE DIAGRAMS

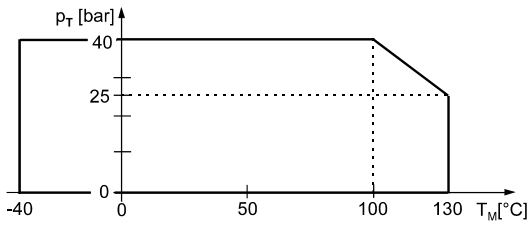

Pressure [ $p_T$ ] as a function of temperature [ $T_M$ ] for all versions (except PP-flanged version)

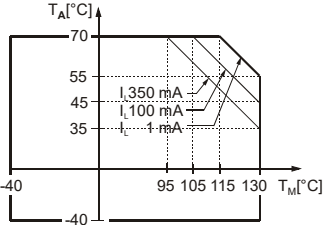

The thermal limits of DC versions, [ $I_L$ ] load current

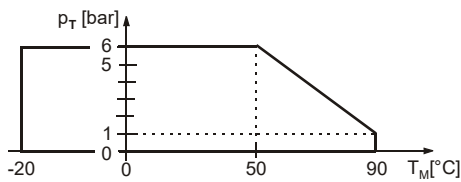

Pressure [ $p_T$ ] as a function of temperature [ $T_M$ ] for PP flanged version

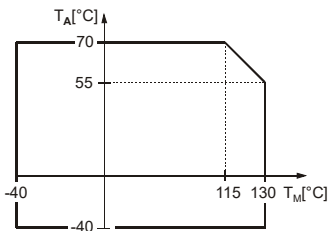

Temperature limits of AC versions, [ $T_A$ ] ambient temperature [ $T_M$ ] medium temperature

## 2.7 RESPONSE TIME DIAGRAM

(when the level of the medium drops below the fork)

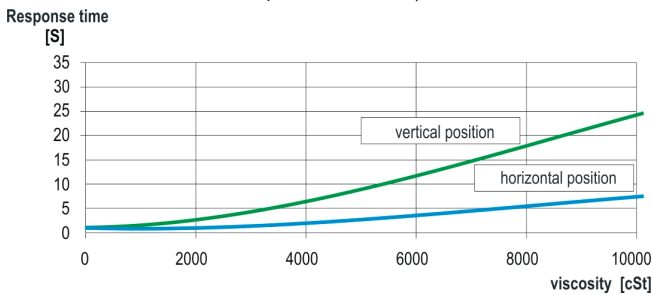

## 2.8 DIMENSIONS

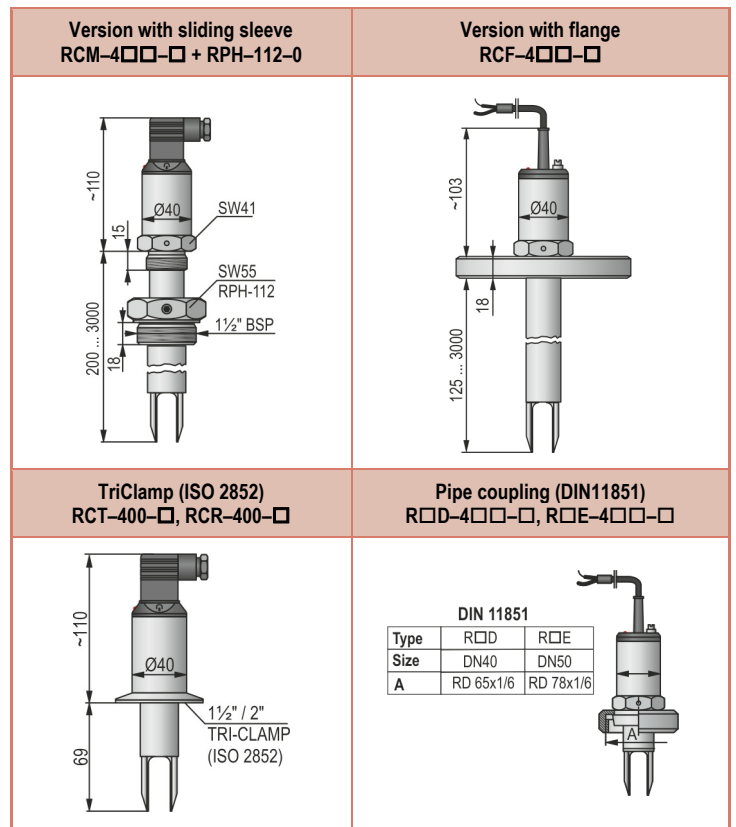
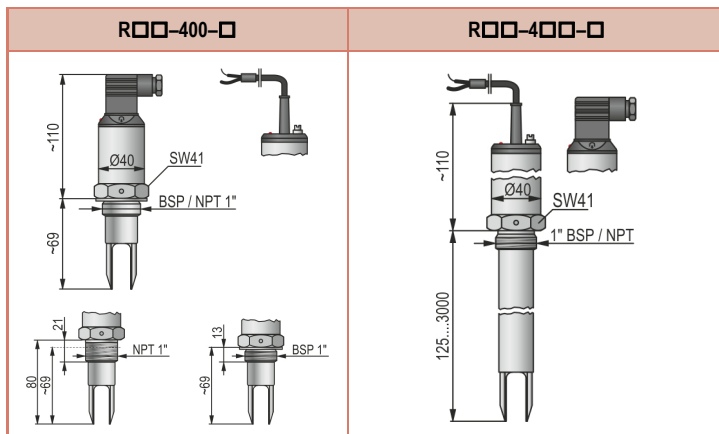

## 2.9 MATERIALS

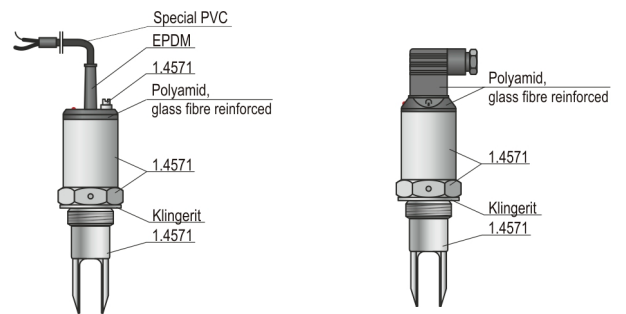

## 3. INSTALLATION

Protect the device from any mechanical damage.

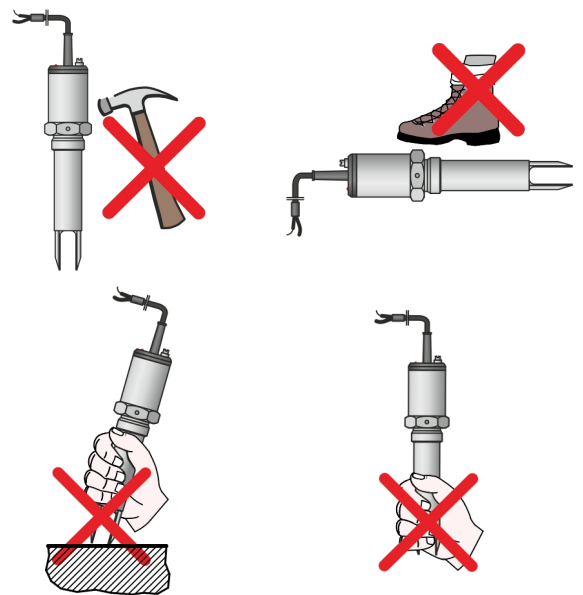

To adjust the position of prongs use the marking on the hexagonal neck.

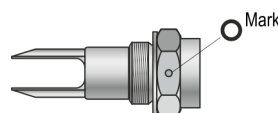

- If the prongs have to be positioned directionally (side mounting), use PTFE tape to seal the thread and position the prongs.
- In this case, vertical positioning of the fork is suggested.

### Low-viscosity liquids

If the measured medium is a low-viscosity liquid, the position of the prongs is irrelevant.

### High-viscosity liquids

If the measured medium is highly viscous, mounting the fork horizontally is recommended.

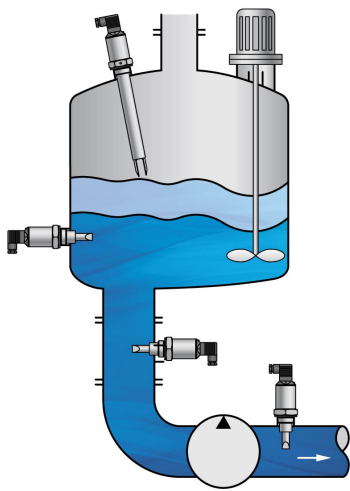

Installation options

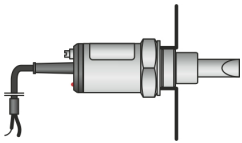

Threaded version

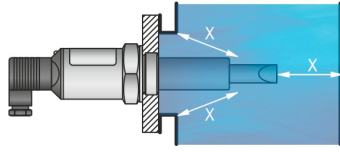

Flanged version, critical distances  $x > 5 \text{ mm (0.2")}$

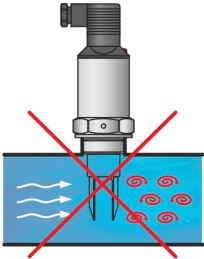

For pipe mounting, the prongs must be parallel to the direction of flow

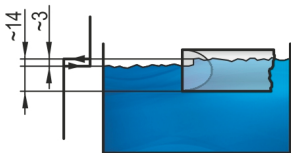
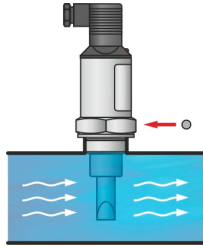

Switching point and differential for water at 25 °C (77 °F)

The switching point, and the switching differential, depends on the liquid density and mounting position.

## 4. WIRING

### 4.1 3-WIRE AC VERSIONS R□□-4□□-1 (connector) R□□-4□□-2 (cable)

**Do not power up the device without a load connected in series with the unit and without grounding it!**

#### 4.1.1 Version with connector R□□-4□□-1

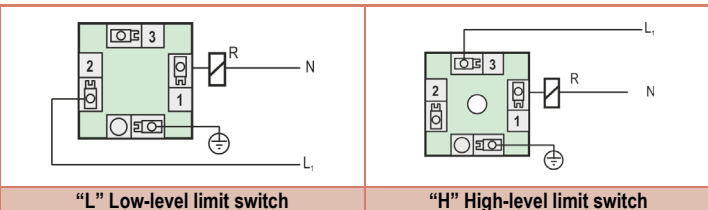

The terminal block cover can be rotated in 90° steps to ensure appropriate cable positioning.

#### 4.1.2 Version with cable R□□-4□□-2

This version is equipped with a 4-wire cable. Only one of the black and brown wires is used, depending on the operating mode (high or low).

Connect the unused wire to an unused terminal in the terminal block.

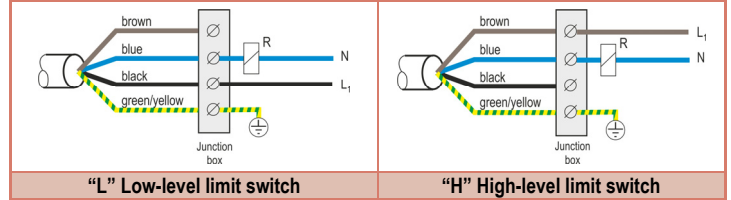

### 4.2 3-WIRE DC VERSIONS

If there is overload caused by a short circuit, the transistor will switch on and off, and the LED will start to blink.

#### 4.2.1 Version with connector R□□-4□□-M, R□□-4□□-3

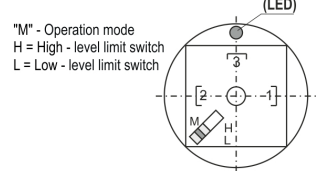
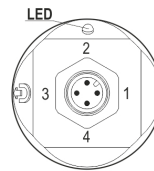

"M" - Operation mode  
H = High - level limit switch  
L = Low - level limit switch

#### 4.2.1.1 Wiring of the 3-wire DC version with connector in a relay application

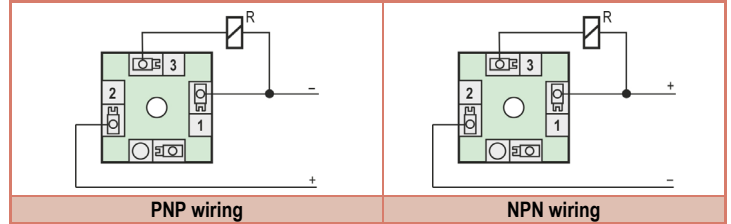

The terminal block cover can be rotated in 90° steps to ensure appropriate cable positioning.

#### PNP output

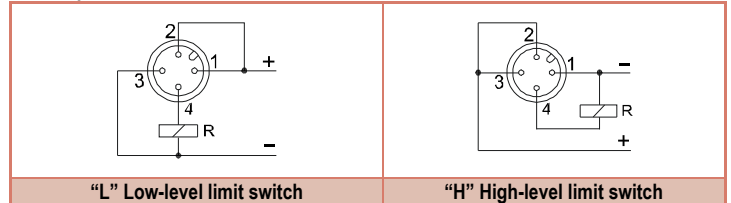

#### NPN output

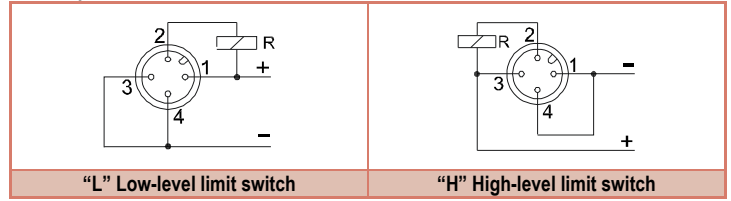

#### 4.2.1.2 Wiring of 3-wire DC version with connector in case of PLC application

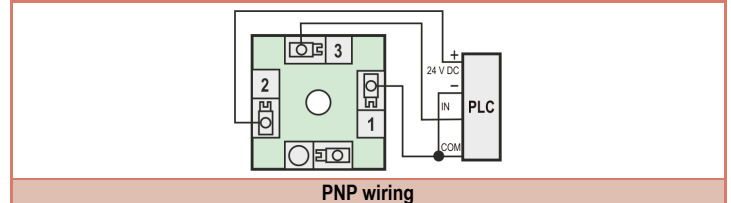

#### 4.2.2 Version with cable R□□-4□□-4

##### 4.2.2.1 Wiring in case of relay applications

#### PNP output

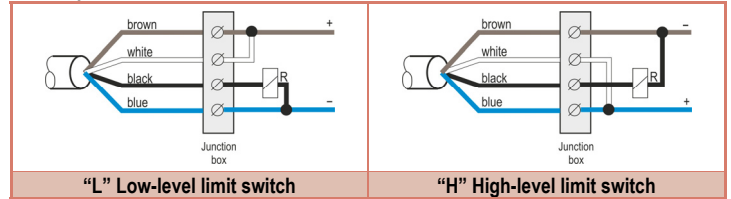

## NPN wiring

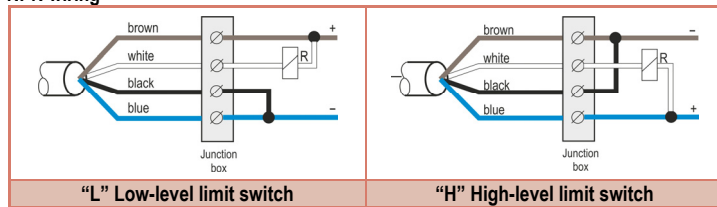

### 4.2.2.2 Wiring in case of PLC applications

## PNP wiring

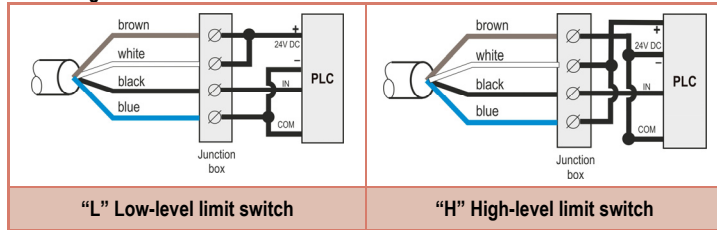

## 4.3 2-WIRE DC VERSIONS, NORMAL OR EX

### 4.3.1 Version with connector

R□□-4□□-6  
R□□-4□□-8 Ex

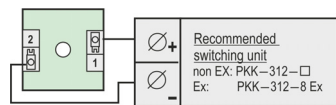

R□□-4□□-K  
R□□-4□□-L Ex

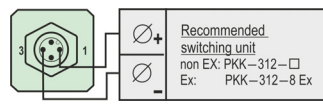

### 4.3.2 Version with cable

R□□-4□□-7  
R□□-4□□-9 Ex

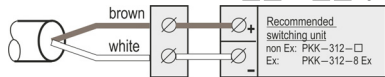

## 5. COMMISSIONING AND, ADJUSTMENT

Check the wire connections and the position of the operating mode switch (if there is one). After connecting and powering up, the vibrating fork is operational.

The operating diagram of the NIVOSWITCH:

Power supply	Fork	Mode	Display (LED)	Output
ON	Immersed	High	Red	OFF
		Low	Green	ON
	Free	High	Green	ON
		Low	Red	OFF
NONE	Free or immersed	H or L	Off	OFF

### Operation diagram of the 2-wire DC version

Fork	Display (LED)	Output
Immersed	Red	14 ± 1 mA
Free	Green	9 ± 1 mA

## OPERATION TEST

The correct operation of the switching circuit of an installed device can be tested with the optional test magnet (RPS-101).

Moving the test magnet in front of the mark on the cover of the housing, the device will perform a switching (LED changes color).

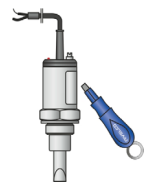

### 5.1 APPLYING EX APPROVED MODELS

When using an Ex-approved model, mind the table of thermal limits below.

Temperature classification	T6	T5	T4
T <sub>ambient</sub>	70 °C (158 °F)	60 °C (140 °F)	60 °C (140 °F)
T <sub>medium</sub>	70 °C (158 °F)	75 °C (167 °F)	130 °C (266 °F)

Table of possible temperatures

### Recommended Installation

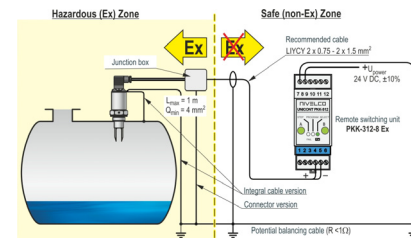

### 5.2 CONDITIONS OF SAFE OPERATION

⊕ II 1G Ex ia IIC T6...T4 Ga and ⊕ II 1G Ex ia IIB T6...T4 Ga approved vibrating forks must be powered by intrinsically safe [Ex ia IIC or IIB] certified and approved devices.

These units must be cleaned only with a damp cloth.

A junction box must be used to wire the cable connection version R□□-4□□-9 Ex devices. The junction box must meet the applicable safety requirements.

The instrument has built-in overvoltage protection, so:

- Outer grounding of the housing must be connected to the steel silo wall with a minimal 4 mm<sup>2</sup> (AWG12), shielded copper cable — outside the Zone 0 — within 1 m (3.3 ft) of the boundary of the Zone 0.
- According to 6.3.12 of EN 60079-11, the standard dielectric strength test must not be performed on the instrument.

To avoid the accumulation of electrostatic charge when using the coated version of the R□□-4□□-□ the following safety rule must be observed:

- The measured medium must be electrostatically conductive, the electrical resistivity of the medium must be ≤ 10<sup>4</sup> Ω.
- The speed of the filling and emptying process must be chosen properly according to the measured medium.

## 6. MAINTENANCE AND REPAIR

The sensor probe may need occasional cleaning to remove surface deposits. This must be carried out gently, without harming the vibrating section of the vibrating fork.

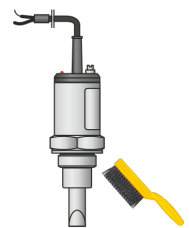

Before returning the device for repairs, it must be cleaned thoroughly. The parts in contact with the medium may contain harmful substances; therefore, they must be decontaminated. Our official form ([Returned Equipment Handling Form](#)) must be filled and enclosed in the parcel. Download it from our website [www.nivelco.com](http://www.nivelco.com). The device must be sent back with a declaration of decontamination. A statement must be provided in the declaration that the decontamination process was successfully completed and that the device is clean from any hazardous substances.

## 7. STORAGE CONDITIONS

Ambient temperature: -40...+70 °C (-40...+158 °F)  
Relative humidity: max. 98%

rsm400en2112h  
September 2021

NIVELCO reserves the right to change anything in this manual without notice!